

Southern Machinery feeder solutions for SMT &THT

Enhancing efficiency and precision in electronics manufacturing, including axial, radial, tube, vibratory bowl, belt, label, and tray types

- Designed to automate the handling and placement of various electronic components,
- From standard to odd-form parts.
- Programmable controls,
- High compatibility with ANY SMT machines,
- Robust construction, and improved labor utilization,
- Aiming to reduce manufacturing costs and boost productivity in smart factories



Specialized in Design And Manufacturing SMT THT Machine

Add: Room 1806, Block 3, Jinyun COFCO, Qianjin 2nd Road ,Baoan District, Shenzhen City, CN 518102
TEL: 0755-83203237; FAX:0755-23240492 Website: www.SMThelp.com

info@SMThelp.com

SAF1001 Axial Tape Feeder

Functional features:



- Integrates with SMT machines for auto insertion, saving labor, and boosting machine utilization
- Supports various non-standard equipment, reducing design cycles and improving stability and utilization..
- Achieves precise U-shaping and lead trimming for relays through an efficient linkage mechanism.
- Enables automated production with robotic arms, replacing manual labor.
- Processes components such as horizontal resistors, diodes, and braided jumpers (JW).
- Offers an optional paper tape return

Category	Parameter	Specification
Overall Dimensions	Length×Width×Height	730×95×212mm
	Weight	8Kg
Applicable Materials	Material Types	Taped resistors, taped triodes, taped jump wires
	Material Size	3×3mm-6×20mm
	Tape Width of Materials	35mm,64mm,92mm(customized according to different widths)
	Thickness of Taping Paper	>0.2mm
Structural Parts	Feeding Method	Horizontal taping tray, incoming materials in boxes
	Feeding Power	Air cylinder forward-pushing type
	Material Positioning Method	Optical fiber sensing + air cylinder fine-tuning
	Fixing Method	Positioning key + pressing block, supports other fixed structures
	Waste Tape Recycling	Front-end vertical dropping(reflow type can also be selected)
Electrical Parts	Working Voltage	24V
	Average CurrentPeak Current	1A3A
	Working Air Pressure	0.4-0.6Mpa
	Operation Mode	Button operation
	Upper Computer Connection	8-core e16mm aviation plug
	Communication Mode	Supports IO communication or self-control without communication
	Software Control	Developed based on PLC
	Drive Mode	Solenoid valve
Feeding Parts	Feeding Speed	0.8S
	Speed Gear	Air pressure speed regulation
	Feeding Accuracy	±0.3mm
Detection Records	Feeding Test	Achieve 1000 consecutive feeding times without abnormality
	Aging Test	Continuous operation for 48 hours without abnormality
	Service Life	1 years

SRF1001 Radial Tape Feeder

Functional features:

- Automates feeding, shaping, cutting, and bending of radial components.
- Integrates with SMT machines for automatic DIP insertion, saving labor and boosting utilization.
- Customizable for odd-form and non-standard equipment, offering tape cutting and component bending options



Category	Parameter	Specification
Overall Dimensions	Length×Width×Height	720×92×165mm
	Weight	10Kg
Applicable Materials	Material Types	Electrolytic capacitors, Y-capacitors, square capacitors, terminals, springs, bent resistors
	Outline Dimensions	2×2×3-15×15×30mm
	Wire Diameter	Wire core:0.3-1.0mm
	Cutting Length	3-6mm(length adjustable)
Structural Parts	Tape Hole Pitch	12.7mm and 15mm(these two are not interchangeable)
	Feeding Method	Vertical tape feeding
	Feeding	Motor drives two feeding wheels for feeding
	Cutting Function	Made of imported materials, cutting length adjustable
	Shaping Function	Replace different shaping molds according to the distance between material
	Bending Function	Can bend components at 90° (this function is optional)
Electrical Parts	Material Positioning Method	Dividing plates
	Tape Discharging	Transmitted and rotated back through the feeding wheel (the tail can be cut off optionally)
	Working Voltage	24V
	Average CurrentPeak Current	4A/6A
	Working Air Pressure	0.4-0.6Mpa
	Operation Mode	Button operation
	Upper Computer Connection	8-core s 16mm aviation plug
	Communication Mode	Supports IO communication or self-control without communication
Feeding Parts	Software Control	PLC control
	Drive Mode	Stepping motor
	Motor Type	42-type/86-type
	Maximum Motor Speed	600 rpm
	Time for One Action Cycle	1S
Detection Records	Feeding Position Adjustment	Y-direction adjusted by diwiding plates,X-direction adjusted bythe position of limit blocks
	Feeding Accuracy	±0.2mm
	Feeding Detection (With or Without Material)	Detected by front-end optical fiber, alarms when there is no material for 3 consecutive times
Detection Records	Feeding Test	Achieve 1000 consecutive feeding times without abnormality
	Aging Test	Continuous operation for 48 hours without abnormality
	Cutter Service Life	5 million times (the cutter is a consumable)

STF1003 Tube Feeder

Functional features:

- Automate feeding of tube-mounted components, including DIPs and transistors (e.g., for screw locking), for SMT machines, non-standard equipment, and robotic arm integration.
- Saves labor, boosts machine utilization, shortens design cycles, and enhances production stability.
- Various sizes are available to suit specific site needs

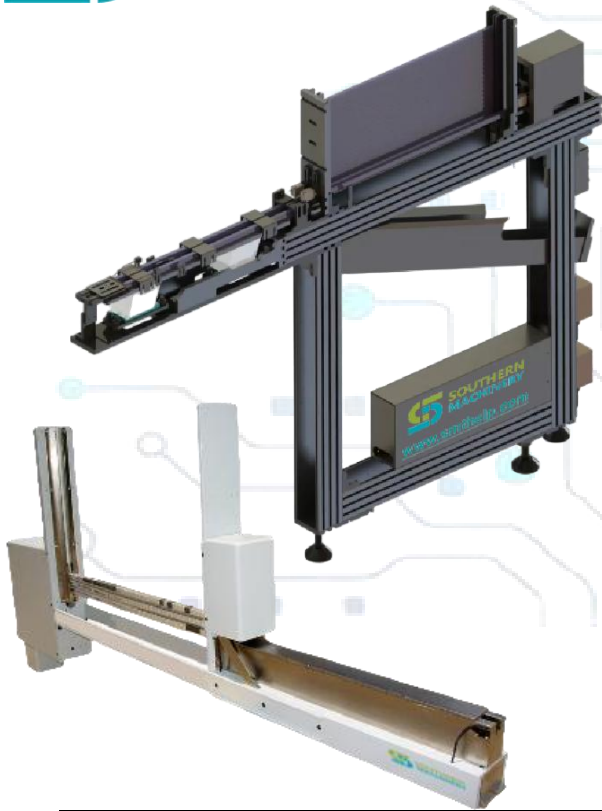

Category	Parameter	Specification
Overall Dimensions	Length × Width × Height	1350 × 92 × 115mm
	Weight	25Kg
Applicable Materials	Material Types	Relays, terminals, transformers, square capacitors, round capacitors
	Material Size	3 × 3 × 3mm-25 × 25 × 25mm
	Tubes	PVC tubes, aluminum tubes
	Tube Length	200-650mm
	Tube Wall Thickness	≥0.6mm
Electrical parts	Feeding Method	Tube-fed incoming materials, multiple tubes stacked
	Feeding Power	Motor-driven spring
	Material Positioning Method	Optical fiber sensing+software compensation
	Fixing Method	Positioning key+pressing block, supports other fixed structures
	Material Receiving Tube	Avoidance via air cylinder, with a recovery box at the bottom
	Working Voltage	24V
	Average Current Peak Current	4A/6A
Feeding parts	Working Air Pressure	0.4-0.6Mpa
	Operation Mode	Button operation
	Upper Computer Connection	8-cores 16mm aviation plug
	Communication Mode	Supports IO communication or self-control without communication
	Software Control	Based on ARM(STC32)
	Drive Mode	Stepping motor
	Motor Type	57-type
	Maximum Motor Speed	600 rpm
Feeding Parts	Feeding Speed	0.8S
	Feeding Channel	Single-channel feeding(dual-channel feeding can be customized)
	Speed Gear	Four-gear adjustable
	Feeding Accuracy	±0.5mm
Detection Records	Feeding Test	Achieve 1000 consecutive feeding times without abnormality
	Aging Test	Continuous operation for 48 hours without abnormality
	Spring Service Life	4 million times of bending resistance life

SBF1001 Bowl Feeder

Functional features:

- Automates bulk component feeding for SMT THT machines and equipment,
- Boosting utilization and saving labor.
- It sorts, screens (direction/polarity), cuts, and shapes materials, enabling robotic integration for automated production

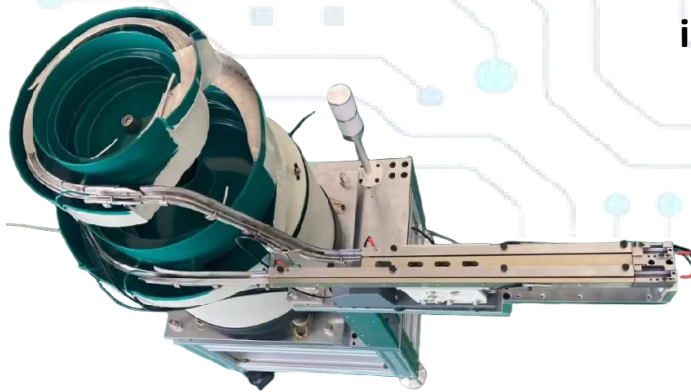

Category	Parameter	Specification
Overall Dimensions	Front and Rear Bowls) LxWxH)	1120×460×910mm
	Length×Width×Height(Single Bowl)	760×460×910mm
	Weight	Double bowls:190Kg;Single bowl:150Kg
Applicable Materials	Material Types	Electronic components,hardware parts,plastic parts,connectors
	Material Size	3×3mm-50×50mm
	Material Weight	10g-300g
Structural Parts	Feeding Method	Bulk feeding,vibratory bowl feeding
	Feeding Bowl Surface	Single bowl feeding,front and rear bowls feeding
	Material Conveyance	Relyon direct vibration+air blowing for conveyance
	Material Positioning Method	Optical fiber sensing
	Fixing Method	Positioning key+clamping block,supports other fixing structures
	Polarity Sorting	Optional function based on material requirements
	Lead Cutting	Optional function based on material requirements
Electrical Parts	Working Voltage	220V
	Average Current/Peak Current	3A/5A
	Working Air Pressure	0.4-0.6Mpa
	Operation Method	Button operation
	Upper Computer Connection	8-core s 16mm aviation plug
	Communication Method	Supports IO communication or self-control without communication
	Software Control	Developed based on PLC
Feeding Parts	Driving Method	Coil driving
	Feeding Speed	0.8S
	Speed Gears	Voltage and frequency adjustment
Inspection Records	Feeding Precision	±0.5mm
	Feeding Test	Achieve 2-hour continuous feeding without abnormality
	Aging Test	Continuous operation for 48 hours without abnormality

SBF2002 Belt Feeder

Functional features:

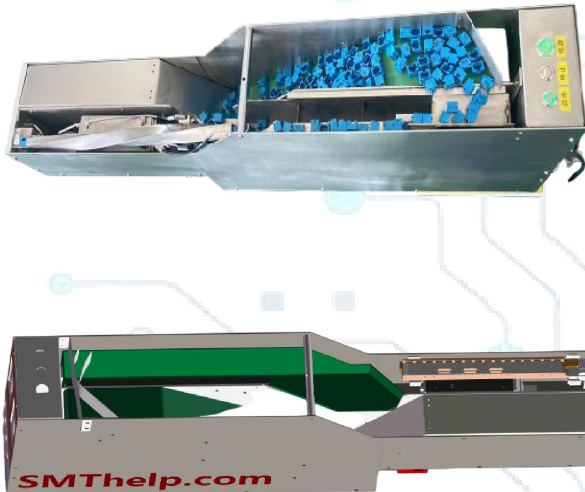

- Automates bulk material feeding, saving packaging costs
- It's compact, quiet, and quickly replaceable,
- Offering high versatility for multi-pin components
- It includes material selection and NG return,
- Compatible with any placement machine

Category	Parameter	Specification
Dimensions	Length xWidth xHeight	850x140×260mm
	weight	12Kg
Applicable materials	Material Type	Connector,buzzer,network port,terminal,square capacitor
	Material size	3×3×3mm-20×20×20mm
	Material characteristics	Materials have distinct characteristics and can be distinguished physically; Physical features are not obvious and need to be divided into directions
	Unsuitable materials	Pins are easily deformed; Length to height ratio less than 1:1.2
Structural parts	Feeding method	Bulk material
	Feeding power	Motor driven belt feeding+direct vibration feeding
	Material positioning method a fixed way	Fiber opticinduction+direct vibration delay Positioning key + clamping block, supports other fixing structures
Electrical parts	Operating Voltage	220V50HZ
	Average curent/peak current	3A/6A
	working pressure	0.4-0.6Mpa
	Operation method	KeyOperation
	Host computer connection communication method	8-core s 16mm aviation plug Support IO communication or self-control without communication
	Software Control	Based on Mitsubishi (PLC control)
	Drive motor maximum speed	500 rpm
Feeding part	Feeding speed	1.5-2S
	Feed channel	Single channel feeding
	Speed gear	Prossure Debugging
	Feeding accuracy	±1mm
Test records	Feeding test	Achieve 1000 times of continuous feeding without abnormality
	Aging test	Continuous operation for 48 hours without abnormality

SLF1001 Label Feeder

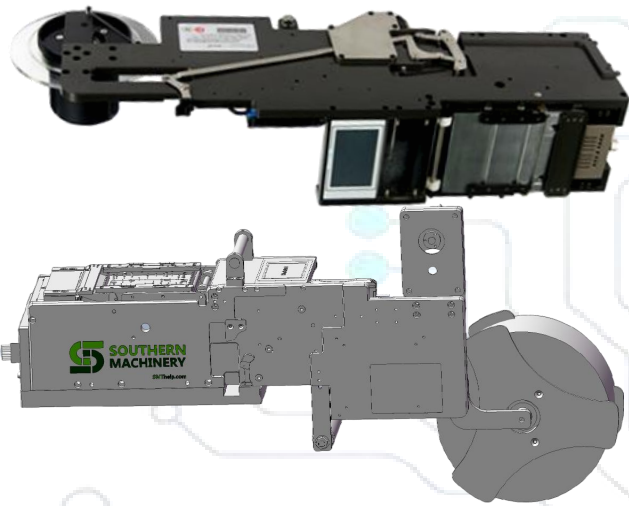

Functional features:

- Automates placement of QR labels for MES.
- Diverse roll materials.
- It handles FPC reinforcement sheets.
- Via robot integration,
- It ensures automated production,
- Saving labor/costs

Category	Parameter	Specification
Overall Dimensions	Length×Width×Height	650×165×320mm
	Weight	7.5Kg
Applicable Materials	Liner Width	Compatible with liners less than 60mm/80mm/100mm
	Liner Thickness	0.05mm-0.08mm
	Material Types	Paper labels, protective films, foam, double-sided adhesive, conductive adhesive or copper foil and steel sheet and other roll-packaged materials
	Material Size	min≥3mm,MAXsliner width
	Inner Diameter of Material Tray Maximum Load of Material Tray	Standard 3-inch core,other specifications can be customized ≤3Kg
Structural Parts	Feeding Method	Roll stripping method
	Material Receiving Platform	High-density foam or polymer anti-sticking material
	Optical Fiber Path	Standard"1 in 1"to "1 in 12"optional
	Amplifier	Standard 1 independent amplifier
	Material Positioning Method	Optical fiber sensing+software compensation
	Feeding Method	Threaded feeding
	Fixing Method	Positioning key+clamping block,supports other fixing structures
Electrical Parts	Liner Rewinding Method	Standard lower belt conveyor for liner rewinding,supports independent motor for liner rewinding
	Material Hanging Tray Shaft Tightening Method	Standard claw clamping structure, supports air-expanded shaft tightening
	Working Voltage	24V
	Average Current/Peak Current	1.5A3A
	Working Air Pressure	0.4-0.6Mpa
Feeding Parts	Operation Method	Button operation
	Upper Computer Connection	8-cores 16mm aviation plug
	Communication Method	Supports IO communication or self-control without communication
	Software Controll	Based on ARM(STC32)
	Driving Method	Stepper motor
	Motor Type	42 type
Inspection Records	Maximum Motor Speed	600 rpm
	Number of Single-time Feeding	Single-row multiple columns,supports multi-row expansion
	Speed Gears	Four gears adjustable
	Feeding Position Adjustment	x-direction limit adjustment+Y-direction software adjustment+Z-direction mechanical adjustment
	Feeding Precision	x-direction ±0.2mm,Y-direction ±0.2mm
Inspection Records	Feeding Rate	≤0.5%
	Feeding Test	Achieve 500 times of continuous feeding without abnormality
	Aging Test	Continuous operation for 48 hours without abnormality

Specialized in Design And Manufacturing SMT THT Machine

Add: Room 1806, Block 3, Jinyun COFCO, Qianjin 2nd Road ,Baoan District, Shenzhen City, CN 518102
TEL: 0755-83203237; FAX:0755-23240492 Website: www.SMThelp.com

info@SMThelp.com

SJF1001 Jumper Wire Feeder

Functional features:

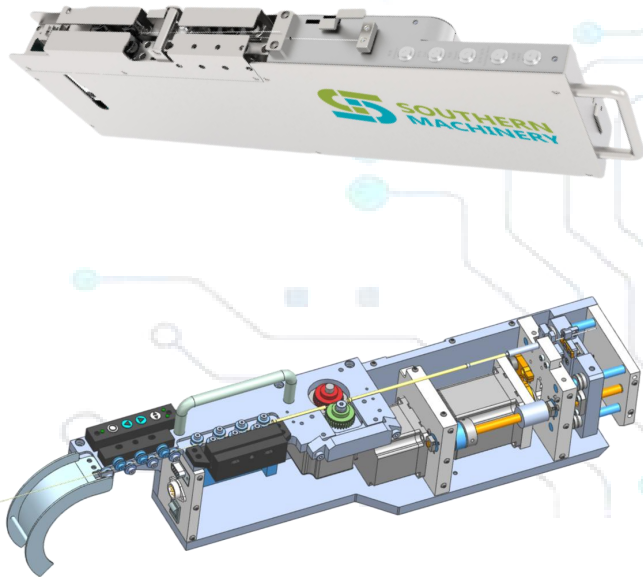

- Fast, high-precision feeding via motor, ratchet, and photoelectric sensors.
- Automates waste-free cutting, forming, and feeding for rolled copper wires ($\phi 0.5-1.2\text{mm}$).
- Rapid 5-minute mold changes enable adjustable pin span (6-40mm), length (3-5mm)
- Feeding length, with adjustable straightening.

Category	Parameter	Specification
Basic Equipment Specifications	Dimensions (L×W×H)	580×50×180mm
	Power Supply Requirements	24VDC/50HZ, Power 150W
	Air Source Requirements	None
	Feeding Speed	≤1.5S/piece
	Station Occupancy	1
Material Specifications	Wire Diameter	$\phi 0.5-1.2\text{mm}$
	Pin Span	6-40mm
	Pin Length	3-5mm
	Material	Tinned Copper Wire
	Weight per Roll (Including Material)	≤2kg
Control Specifications	Control Mode	single-Chip Microcomputer Program Control
	Signal Sensing	Photoelectric Switch
	Operation Mode	Button Panel Operation
	Fault Alarm	Indicator Light
	Program Import	15-Pin Plug
Core Mechanism Specifications	Feeding Module	Motor+Ratchet+Photoelectric Sens or Combined Feeding
	Forming Mold	Replaceable, Supports Different Spans and Pin Lengths
	Straightening Module	One Set of Adjusting Wheels+One Set of Fixed Wheels
	Moving Cutter Mechanism	Motor+Cam Mechanism+Cutting Cutter+Forming Cutter

STP1001 Tray Feeder

Functional features:

- Automates diverse tray material supply for SMT and auxiliary machines.
- It replaces manual labor via robotic arm integration, enabling automated production
- Supply the tray materials of various 3C products such as transformers, relays, hardware, plastic parts

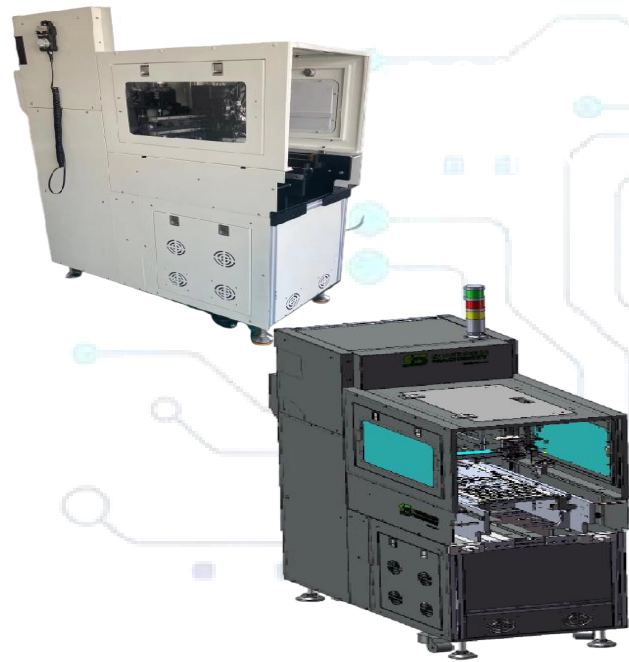

Category	Parameter	Specification
Overall Dimensions	Length×Width×Height	1160×790×1530mm
	Weight	75Kg
Applicable Materials	Material Size	3×3×3mm-50×50×50mm
	Material Types	Transformers,relays,hardware parts,memory module sockets,large capacitors
	Blister Tray Size	150×150-200×300mm
	Blister Tray Material	PET plasticfilm
	Maximum Load of Material Tray	≤3Kg
Structural Parts	Feeding Method	Tray feeding
	TrayLifting Method	Lifting and conveying relying on motor+screw rod
	Tray Conveying Method	Moving the tray back and forth through the conveyor belt
	Fixing Method	Positioning key+clamping block,supports other fixing structures
	Empty Tray Collection Method	Conveying through the belt,sending emptytrays to the lifting platform
	Quantity of Loaded Trays (Height<10mm)	Can load 40 trays
	Quantity of Loaded Trays (Height>10mm)	Can load 20 trays
Electrical Parts	Working Voltage	220V
	Average Current/Peak Current	5A/8A
	Working Air Pressure	0.4-0.6Mpa
	Operation Method	Touch screen+button operation
	Upper Computer Connection	8-core s 16mm aviation plug
	Communication Method	Supports IO communication or self-control without communication
	Software Control	Based on PLC
	Driving Method	Servo motor
	Motor Type	Lifting 400Wservo,conveying 100Wservo motor
	Maximum Motor Speed	3000 rpm
Feeding Parts	Feeding Speed	Time for supplying one material:3S
	Types of Fed Materials	Can supply different types of materials from multiple trays,byswitching trays
	Feeding Precision	±1mm
Inspection Records	Feeding Test	Achieve 500 times of continuous feeding without abnormality
	Aging Test	Continuous operation for 48 hours without abnormality

Specialized in Design And Manufacturing SMT THT Machine

Add: Room 1806, Block 3, Jinyun COFCO, Qianjin 2nd Road ,Baoan District, Shenzhen City, CN 518102
TEL: 0755-83203237; FAX:0755-23240492 Website: www.SMThelp.com

info@SMThelp.com

SSPC101 Solder Chip Feeder

Functional features:

- Automates cutting and feeding of coiled tin sheet/wire for SMT machines and automated lines.
- It integrates with robots for automated, labor-saving production,
- Improving efficiency and stability

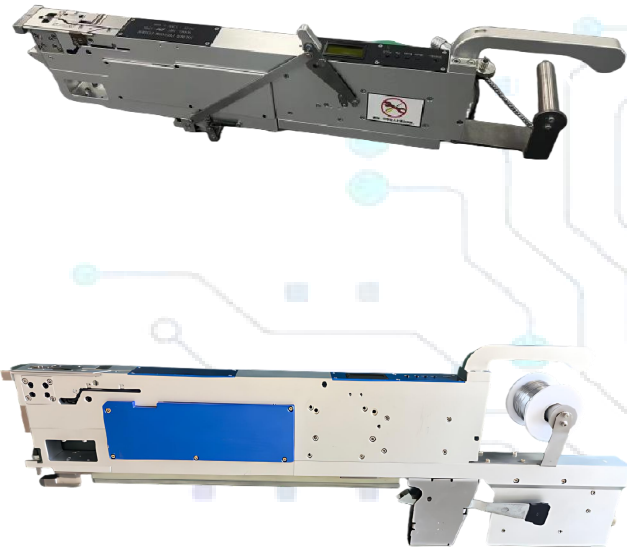

Category	Parameter	Specification
Overall Dimensions	Length×Width×Height	540×115×230mm
	Weight	7Kg
Applicable Materials	Material Size(Width)	Width:1-16mm (Accessories need to be replaced for different widths)
	Material Size(Thickness)	Thickness:0.1-1mm
	Material Types	Solder wire, solder sheet
Structural Parts	Feeding Method	Coil-fed material
	Conveying Method	Feeding by motor propulsion
	Cutting Method	Cutting off by air cylinder driving the cutter
Electrical Parts	Working Voltage	24V
	Average Current/Peak Current	1.5A3A
	Working Air Pressure	0.4-0.6Mpa
	Operation Method	Button operation
	Upper Computer Connection	8-core s 16mm aviation plug
	Communication Method	Supports IO communication or self-control without communication
	Software Control	Based on PLC
	Driving Method	Stepper motor
	Motor Type	42-step motor
Maximum Motor Speed	600 rpm	
Feeding Parts	Feeding Speed	Time for supplying one material:1.2S
	Feeding Precision	±0.5mm
	Material Shortage Detection	Alarm for abnormal feeding when no material is detected for 3 consecutive times
Inspection Records	Feeding Test	Achieve 500 times of continuous feeding without abnormality
	Aging Test	Continuous operation for 48 hours without abnormality

SRT7001 Reel Terminal Feeder

Functional features:

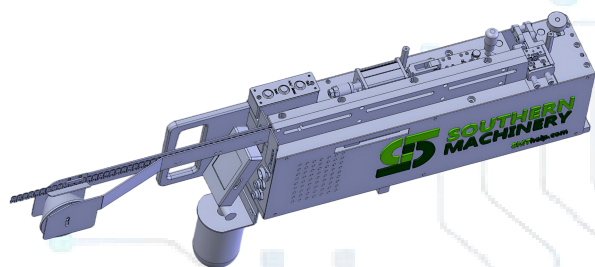

- Automates cutting and feeding of Reel Terminal for SMT THT machines and automated lines.
- It integrates with robots for automated, labor-saving production,
- Improving efficiency and stability



Category	Parameter	Specification
Overall Dimensions	Length×Width×Height	550×130×110mm
	Weight	10 Kg
Applicable Materials	Material Size	Tab 6.35 x0.81mm
	Profile Height from PCB	10.21mm
	Material Types	Reel Terminal
Structural Parts	Conveying Method	Feeding by motor propulsion
	Cutting Method	Cutting off by air cylinder driving the cutter
Electrical Parts	Working Voltage	24V
	Average Current/Peak Current	1.5A3A
	Working Air Pressure	0.4-0.6Mpa
	Operation Method	Button operation
	Upper Computer Connection	8-core s 16mm aviation plug
	Communication Method	Supports IO communication or self-control without communication
	Software Control	Based on PLC
	Driving Method	Stepper motor
Feeding Parts	Motor Type	42-step motor
	Maximum Motor Speed	600 rpm
	Feeding Speed	Time for supplying one material: 0.8s
	Feeding Precision	±0.5mm
	Material Shortage Detection	Alarm for abnormal feeding when no material is detected for 3 consecutive times
Inspection Records	Feeding Test	Achieve 500 times of continuous feeding without abnormality
	Aging Test	Continuous operation for 48 hours without abnormality

Special Application Nozzles

Key Features and Performance

- Excellent *hardness* and precision.
- Enhanced durability and wear resistance
- Advanced engineering design

Gripper Nozzles:

- Fixed arm and a swing arm that enables it to grab odd shape
- Used for Odd form components, special connectors, hybrid circuits

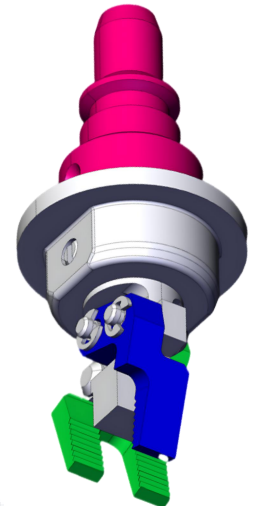

Custom Nozzles:

- Picking and placing THT components
- Interchangeable rubber tips for mounting dies





**Panasonic CM602 odd form machine
install tube feeder+bowl feeder**



**JUKI odd form machine install tube
feeder+bowl feeder+radial tape
feeder**



**YAMAHA odd form machine install
tube feeder**

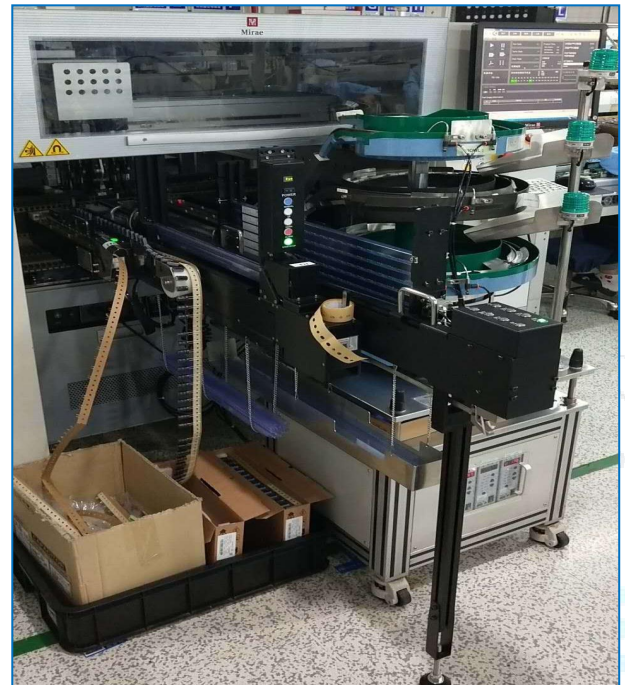

**Mirae odd form machine install tube
feeder+bowl feeder+radial tape
feeder**

Smart SMT reel storage rack

Key Features and Performance

- Simplifies receiving, storage and retrieval
- Delivers full traceability
- Automatically monitors stock levels

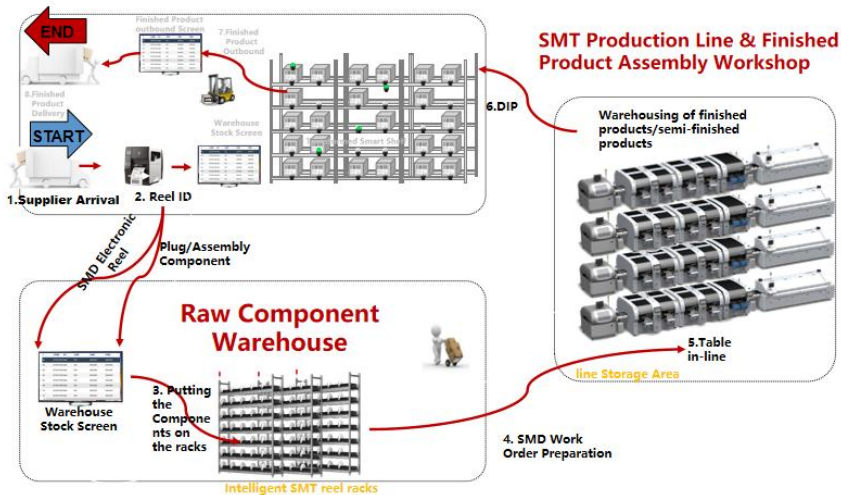
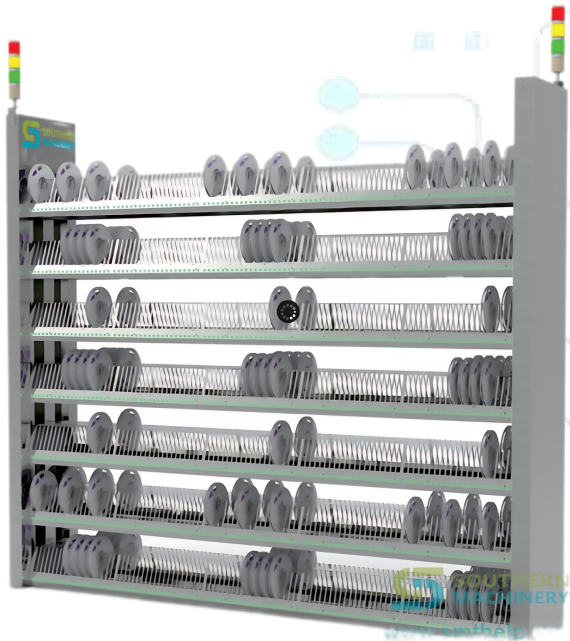

Model	SIS7000A	SIS4000A
Name	7-in SMT reel storage rack	13-in SMT reel storage rack
Overall size(mm)	2170*400*1900	2170*640*1900
single size(mm)	17	40
Layers	7	4
Number of Reels	1400	400
Power (w)	100	100
Function	Storage 7-inch SMT reel	Storage 13-inch SMT reel
Illustrate	Optionally install casters or foot cups	

EMQX: Revolutionizing SMT Material Management with Intelligent Connectivity

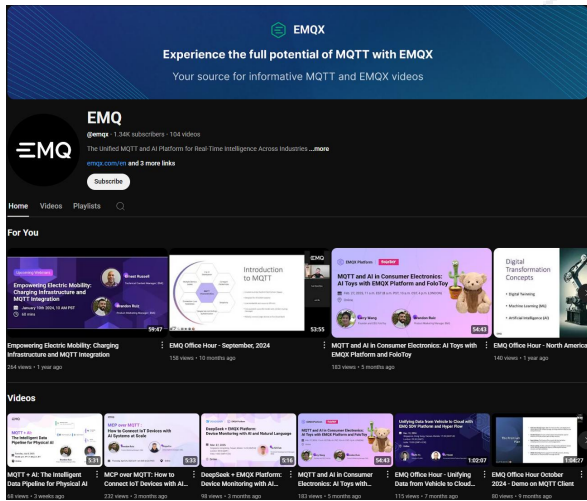

Key Features of EMQX

- Comprehensive Protocol Support
- Massive Scalability & High Availability
- Powerful Rule Engine & Data Integration
- Unified Experience
- Cloud Deployment Options

<https://github.com/emqx/emqx>

<https://www.youtube.com/@emqx>

Benefits for SMT Intelligent Reel Storage Systems:

- Enabling Real-Time Inventory and Traceability
- Seamless Integration with MES/ERP Systems
- Supporting Automation and "Unmanned" Material Flow
- Enhanced Data Management and Analytics
- Scalability for Growing Operations
- Reduced Errors and Improved Efficiency



Specialized in Design And Manufacturing SMT THT Machine

Add: Room 1806, Block 3, Jinyun COFCO, Qianjin 2nd Road, Baoan District, Shenzhen City, CN 518102
TEL: 0755-83203237; FAX: 0755-23240492 Website: www.SMThelp.com

info@SMThelp.com

Your Trusted Partner for SMT & THT Solutions

Founded in Shenzhen in 2011, Southern Machinery specializes in designing and manufacturing advanced SMT/THT machinery for PCB assembly automation. Our precision-engineered equipment delivers cost-effective, high-efficiency solutions for both high-speed mass production and delicate small-batch manufacturing, ensuring durability and user-friendly operation.

Leveraging Shenzhen's electronics manufacturing expertise, we provide not just top-tier machinery but also industry-leading knowledge and best practices to global clients.

Explore our solutions at www.smthelp.com, follow our innovations on:

- [\[LinkedIn Company Page\]](https://www.linkedin.com/company/smtmachine)(https://www.linkedin.com/company/smtmachine)
- [\[LinkedIn Profile\]](https://cn.linkedin.com/in/smtsupplier)(https://cn.linkedin.com/in/smtsupplier)
- [\[Twitter\]](https://twitter.com/smtspecialist)(https://twitter.com/smtspecialist)
- [\[Facebook\]](https://www.facebook.com/autoinsertion)(https://www.facebook.com/autoinsertion)
- [\[YouTube Channel\]](https://www.youtube.com/c/Smthelping)(https://www.youtube.com/c/Smthelping)
- [Browse our machine catalog](https://file.autoinsertion.com) at (https://file.autoinsertion.com)
- [Find machine photos](https://ph.smthelp.com) at (https://ph.smthelp.com)

Shaping the Future of Electronics Manufacturing.

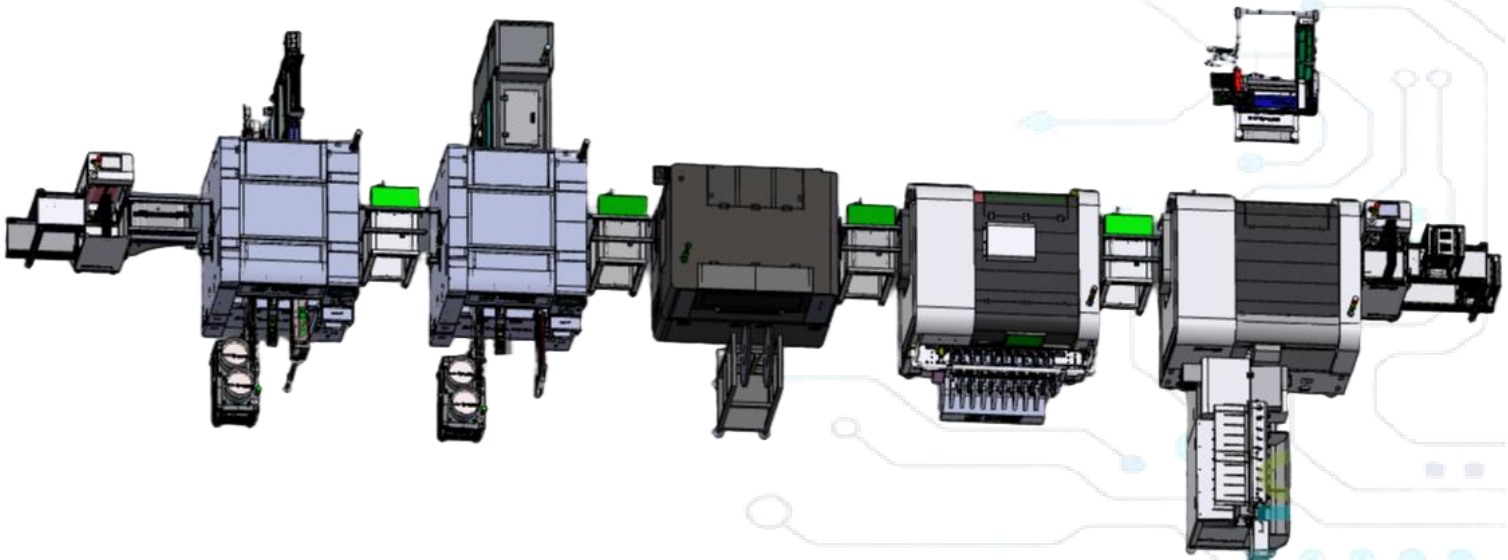

Specialized in Design And Manufacturing SMT THT Machine

Add: Room 1806, Block 3, Jinyun COFCO, Qianjin 2nd Road, Baoan District, Shenzhen City, CN 518102
TEL: 0755-83203237; FAX:0755-23240492 Website: www.SMThelp.com

info@SMThelp.com