

Smart EMS Factory: PCB Conveyor

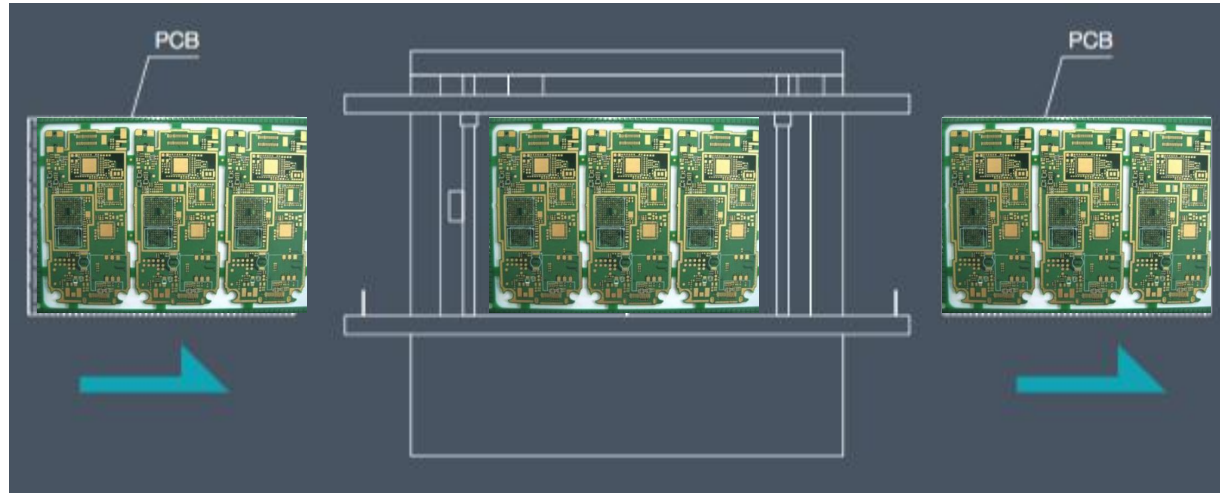

used to link between SMT machines or board handling units.



Smart EMS Factory: PCB Conveyor

FEATURE

- PLC Program control.
- Start / Stop push button.
- Anti-static conveyor belt.
- Easy way of belt replacement.
- Heavy bottom design to prevent shifting.
- PCB precise stopping in position.
- Smooth and parallel width adjustment.(lead screw).
- SMEMA compatible.



Smart EMS Factory: PCB Conveyor

Conveyor	Round or Flat Belt
Transport height	900mm ±30mm
Transfer direction	Left to right or R to L
Operation side	Front of the machine
Fixed rail	Front of the machine
Interface	SMEMA
Conveyer concept	ESD flat belt
Belt speed	0.5-20m/min adjustable
PCB edge support	3mm
Components clearance	Bottom 30 mm or specify
Power supply:	220 VAC/50 Hz/1 Ph
Power consumption	120VA max
Load bearing	1.5kg/PCB



Smart EMS Factory: PCB Conveyor

1. **How length conveyor do you need?**
2. **What is the maximum width of you PCB?**
3. **Do you need inspection with lighting**
4. **Do you need dual rail?**
5. **Do you need cover with cooling fan?**
6. **Do you need buffer bad boards?**
7. **Do you need working table both side?**

Smart EMS Factory: PCB Conveyor

Do you need our professional support to layout your SMT line?

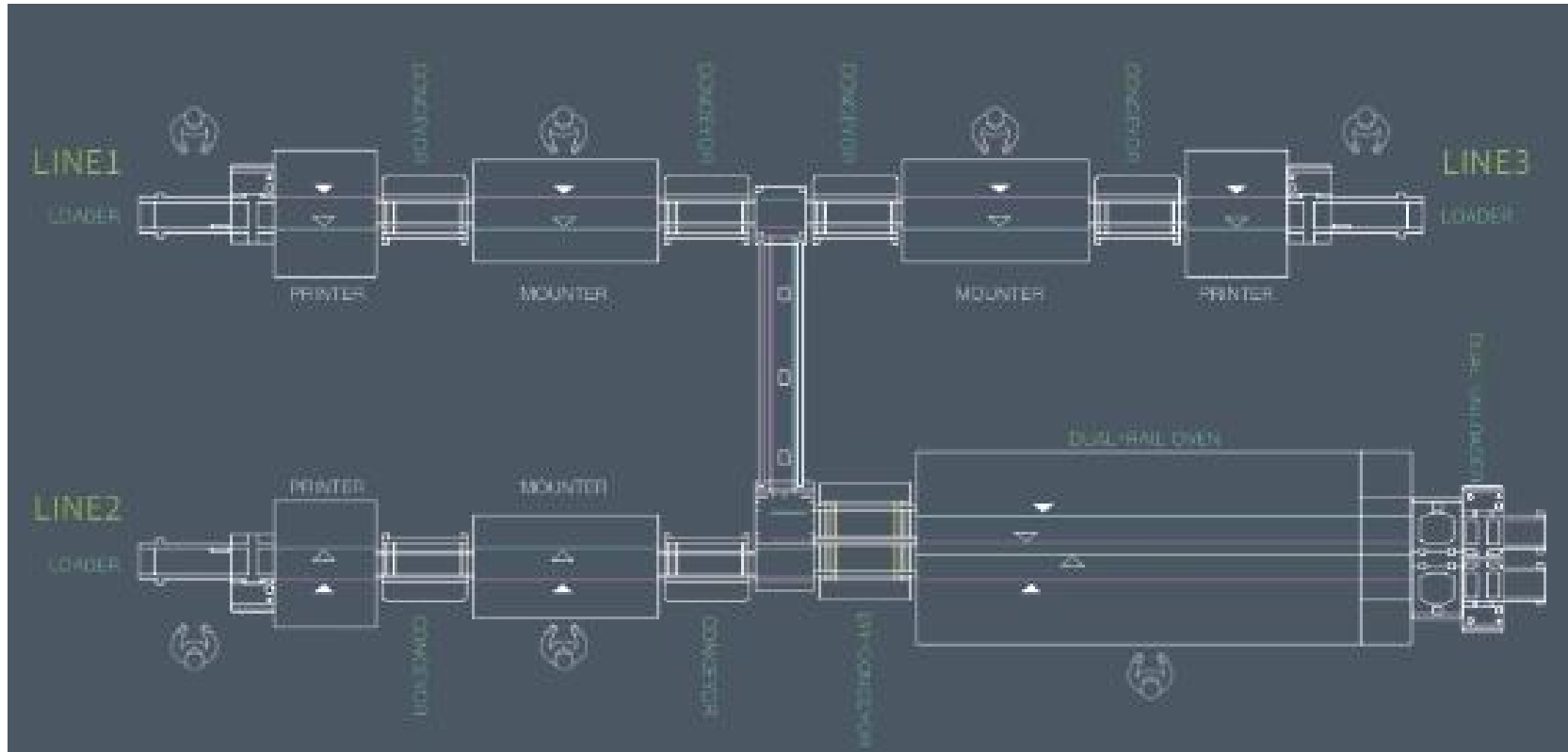

Smart EMS Factory: PCB Conveyor

Single rail conveyor

Item Model	Length (mm)	Max PCB Width(mm)	Remark	U/P(U SD)
1 S-350C	500	350	no Lighting	
2 S-460C	500	460	no Lighting	
3 S-350C-L	500	350	with Lighting	
4 S-460C-L	500	460	with Lighting	
5 S-350D	1000	350	no Lighting	
6 S-460D	1000	460	no Lighting	
7 S-350D-L	1000	350	with Lighting	
8 S-460D-L	1000	460	with Lighting	
9 S-350E	1500	350	no Lighting	
10 S-460E	1500	460	no Lighting	
11 S-350E-L	1500	350	with Lighting	
12 S-460E-L	1500	460	with Lighting	

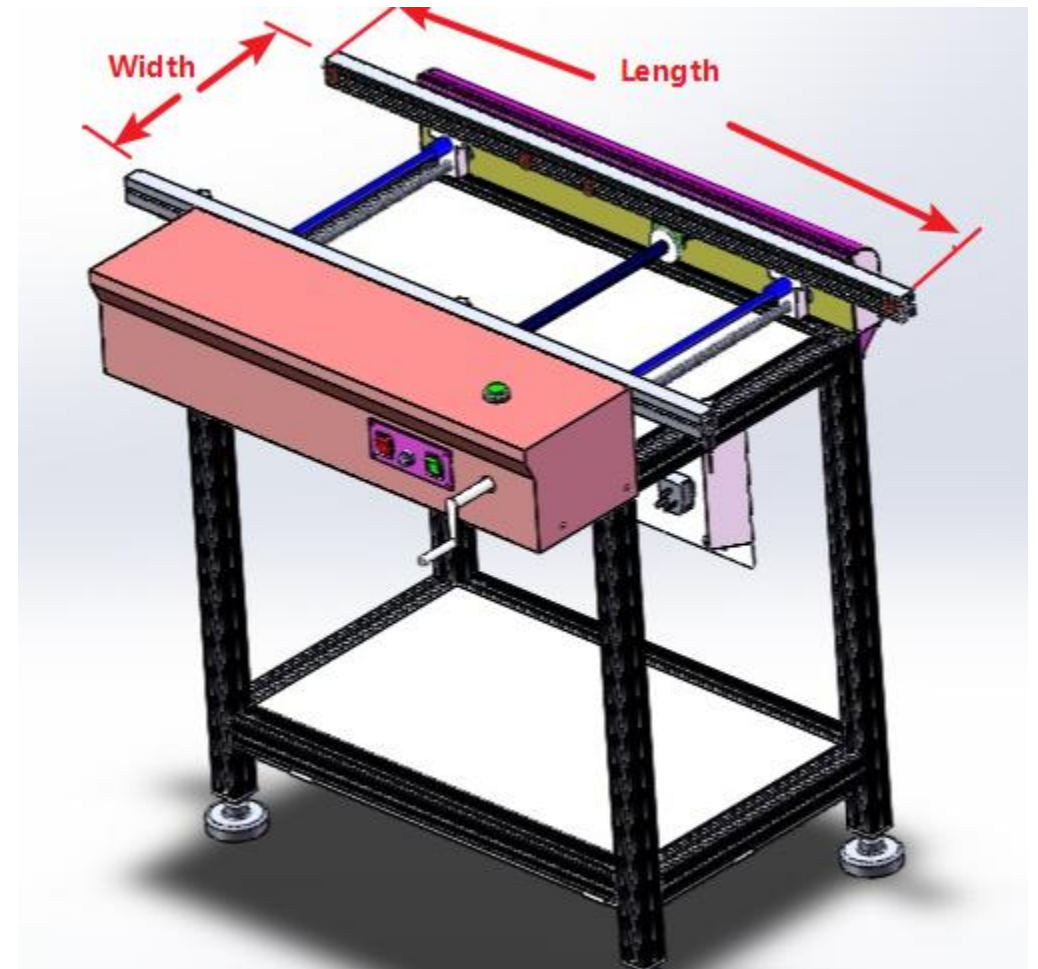

Smart EMS Factory: PCB Conveyor

Dual rail conveyor

Item	Model	Length (mm)	Max PCB Width(mm)	Remark	U/P(USD)
1	S-C250DL	500	250	no Lighting	
2	S-C250DL-L	500	250	with Lighting	
3	S-D250DL	1000	250	no Lighting	
4	S-D250DL-L	1000	250	with Lighting	
5	S-C350DL	500	350	no Lighting	
6	S-C350DL-L	500	350	with Lighting	
7	S-D350DL	1000	350	no Lighting	
8	S-D350DL-L	1000	350	with Lighting	



Smart EMS Factory: PCB Conveyor

Conveyor with Cover and
cooling fan



Smart EMS Factory: PCB Conveyor

1, Please visit : www.smthelp.com

2, Find us more:
<https://www.facebook.com/autoinsertion>

3, Know more our team:
<https://cn.linkedin.com/in/smtsupplier>

4, Welcome to our factory in Shenzhen China

5, See more machine working video, please Youtube:
Auto Insertion

6, Google: Auto+insertion, to get more informations

7, Looking forward to your email: info@smthelp.com

