

Southern Machinery feeder solutions for SMT &THT

Enhancing efficiency and precision in electronics manufacturing, including axial, radial, tube, vibratory bowl, belt, label, and tray types

- Designed to automate the handling and placement of various electronic components,
- From standard to odd-form parts.
- Programmable controls,
- High compatibility with ANY SMT machines,
- Robust construction, and improved labor utilization,
- Aiming to reduce manufacturing costs and boost productivity in smart factories



SJF1001 Jumper Wire Feeder

Functional features:

- Fast, high-precision feeding via motor, ratchet, and photoelectric sensors.
- Automates waste-free cutting, forming, and feeding for rolled copper wires ($\phi 0.5-1.2\text{mm}$).
- Rapid 5-minute mold changes enable adjustable pin span (6-40mm), length (3-5mm)
- Feeding length, with adjustable straightening.

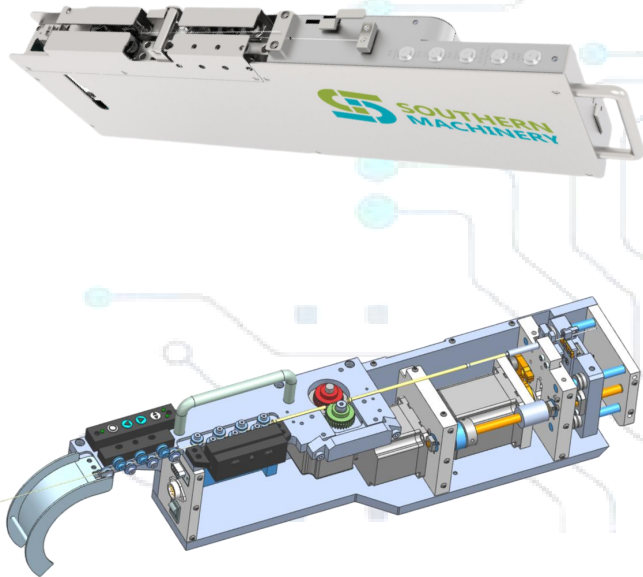

Category	Parameter	Specification
Basic Equipment Specifications	Dimensions (L × W × H)	580 × 50 × 180mm
	Power Supply Requirements	24VDC/50HZ, Power 150W
	Air Source Requirements	None
	Feeding Speed	≤1.5S/piece
	Station Occupancy	1
Material Specifications	Wire Diameter	$\phi 0.5-1.2\text{mm}$
	Pin Span	6-40mm
	Pin Length	3-5mm
	Material	Tinned Copper Wire
	Weight per Roll (Including Material)	≤2kg
Control Specifications	Control Mode	single-Chip Microcomputer Program Control
	Signal Sensing	Photoelectric Switch
	Operation Mode	Button Panel Operation
	Fault Alarm	Indicator Light
	Program Import	15-Pin Plug
Core Mechanism Specifications	Feeding Module	Motor+Ratchet+Photoelectric Sens or Combined Feeding
	Forming Mold	Replaceable, Supports Different Spans and Pin Lengths
	Straightening Module	One Set of Adjusting Wheels+One Set of Fixed Wheels
	Moving Cutter Mechanism	Motor+Cam Mechanism+Cutting Cutter+Forming Cutter



**Panasonic CM602 odd form machine
install tube feeder+bowl feeder**



**JUKI odd form machine install tube
feeder+bowl feeder+radial tape
feeder**



**YAMAHA odd form machine install
*tube feeder***

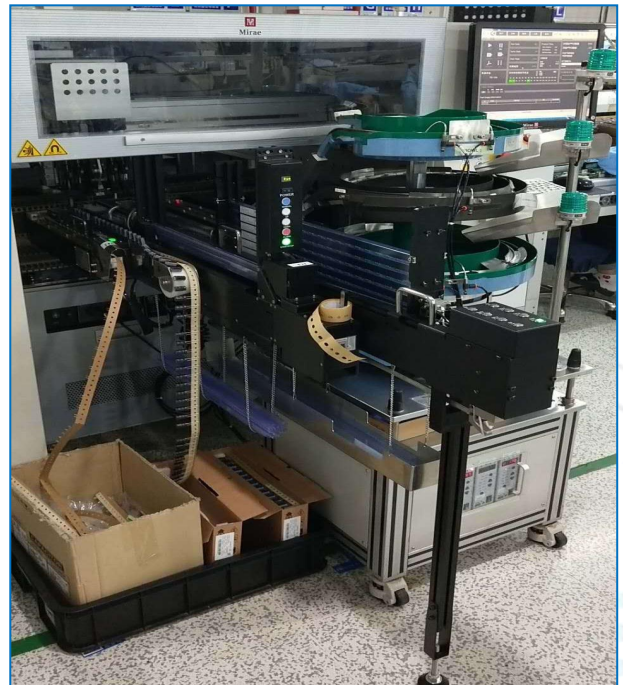

**Mirae odd form machine install tube
feeder+bowl feeder+radial tape
feeder**



Your Trusted Partner for SMT & THT Solutions

Founded in Shenzhen in 2011, Southern Machinery specializes in designing and manufacturing advanced SMT/THT machinery for PCB assembly automation. Our precision-engineered equipment delivers cost-effective, high-efficiency solutions for both high-speed mass production and delicate small-batch manufacturing, ensuring durability and user-friendly operation.

Leveraging Shenzhen's electronics manufacturing expertise, we provide not just top-tier machinery but also industry-leading knowledge and best practices to global clients.

Explore our solutions at www.smthelp.com, follow our innovations on:

- [\[LinkedIn Company Page\]](https://www.linkedin.com/company/smtmachine)(https://www.linkedin.com/company/smtmachine)
- [\[LinkedIn Profile\]](https://cn.linkedin.com/in/smtsupplier)(https://cn.linkedin.com/in/smtsupplier)
- [\[Twitter\]](https://twitter.com/smtspecialist)(https://twitter.com/smtspecialist)
- [\[Facebook\]](https://www.facebook.com/autoinsertion)(https://www.facebook.com/autoinsertion)
- [\[YouTube Channel\]](https://www.youtube.com/c/Smthelping)(https://www.youtube.com/c/Smthelping)
- [Browse our machine catalog](https://file.autoinsertion.com) at (https://file.autoinsertion.com)
- [Find machine photos](https://ph.smthelp.com) at (https://ph.smthelp.com)

Shaping the Future of Electronics Manufacturing.

