

1. We have different original spare parts' drawings, though our spare parts are high copy, we can manufacture **the same quality as the original**, and the price is **lower than the original 10 times**. At the same time, we promise enough life of spare parts 100%.

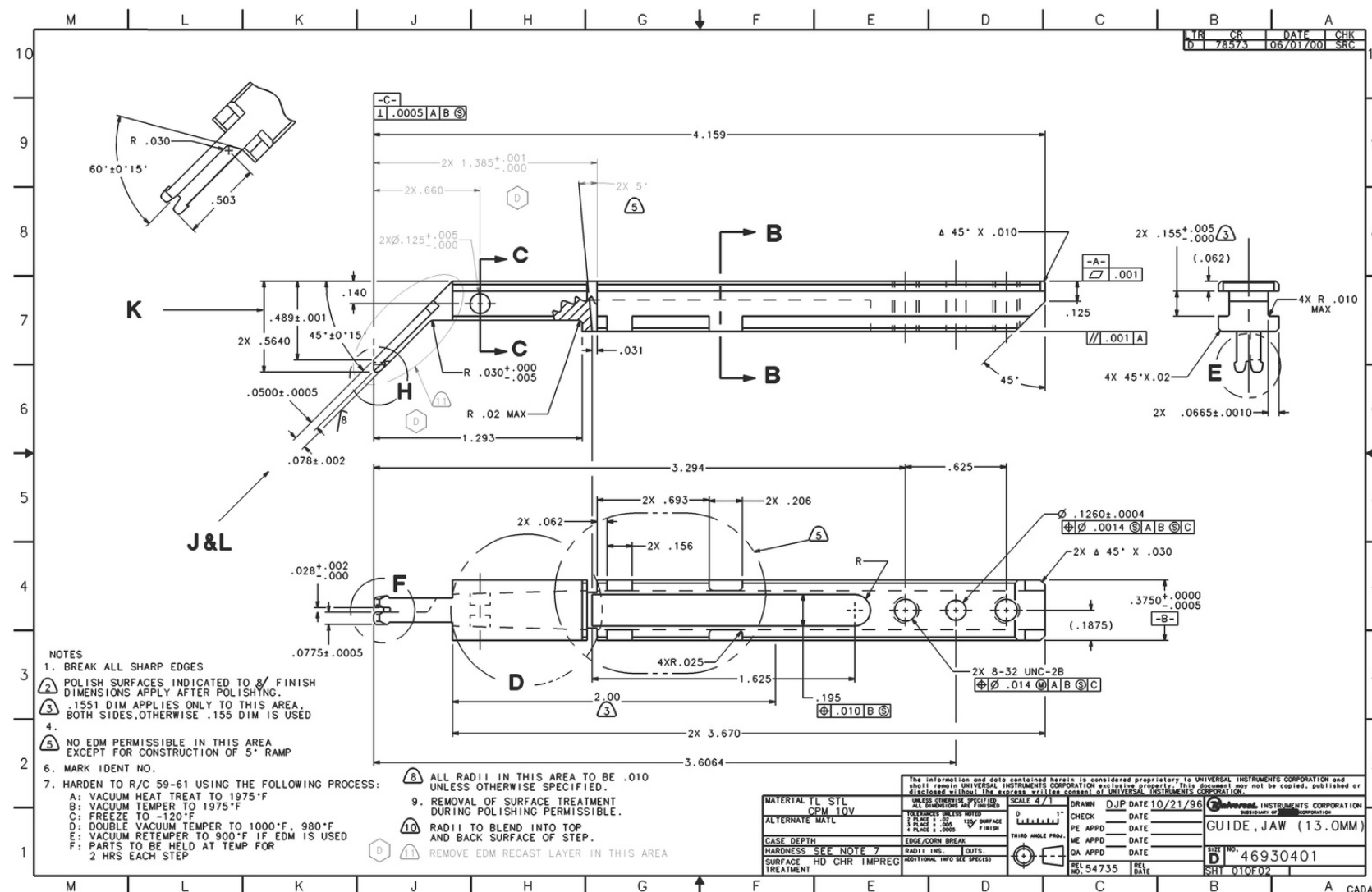

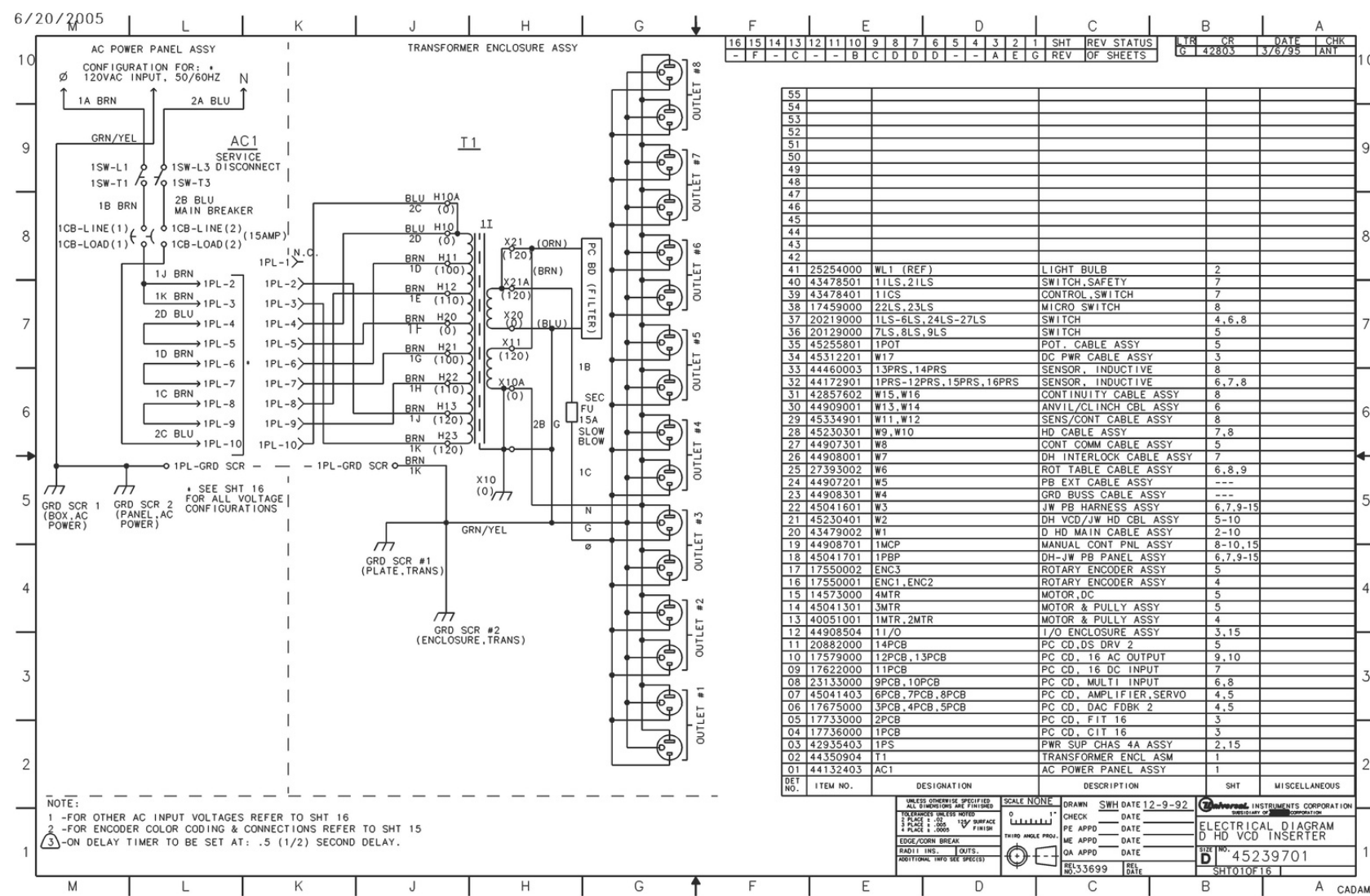

2. Provide different spare parts and wearing parts of different brands and models.  
(UIC,TDK,Panasonic,Samsung,Fuji,Juki,SIMMENS.....) Only need to tell us your  
parts' machine model and P/N.

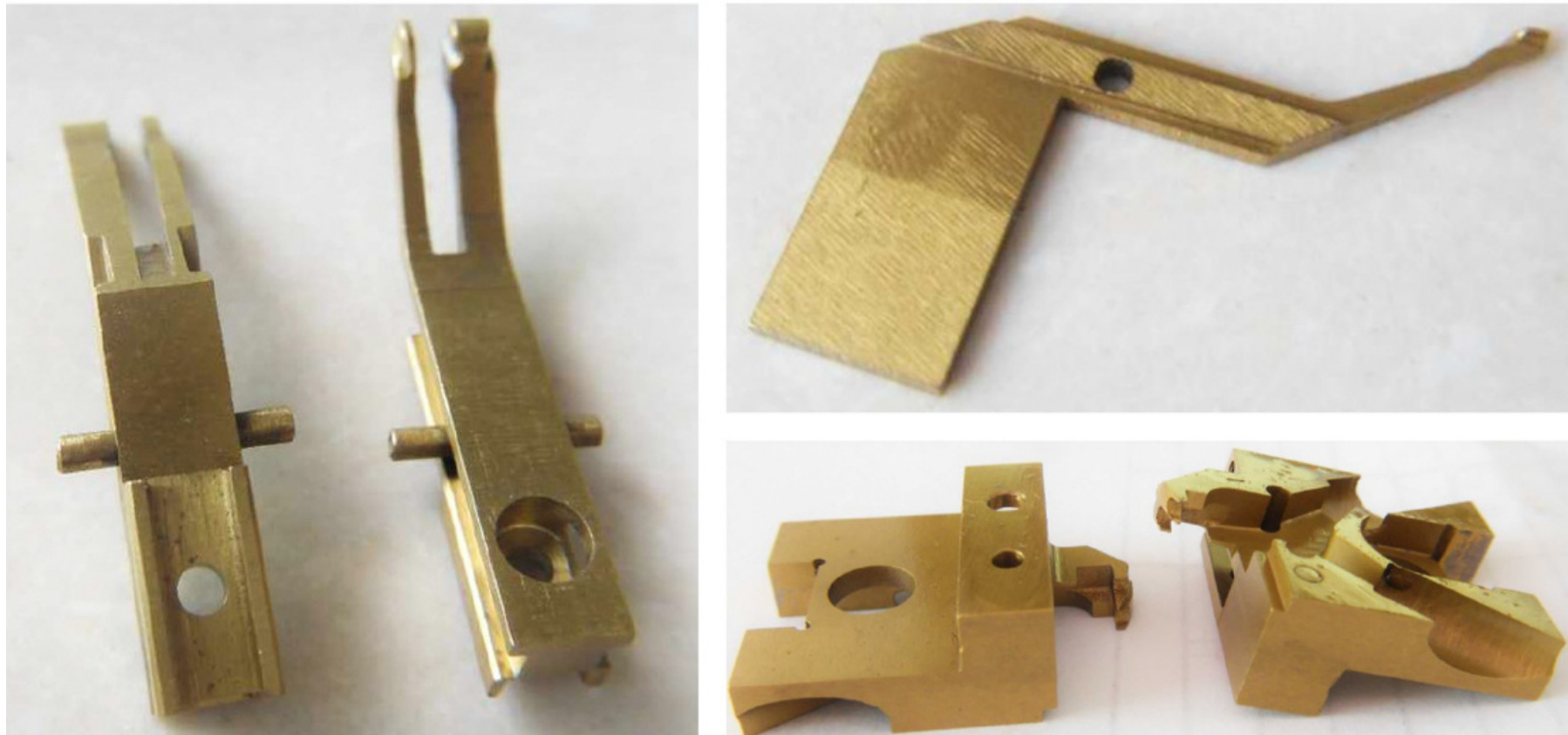

TDK



UIC

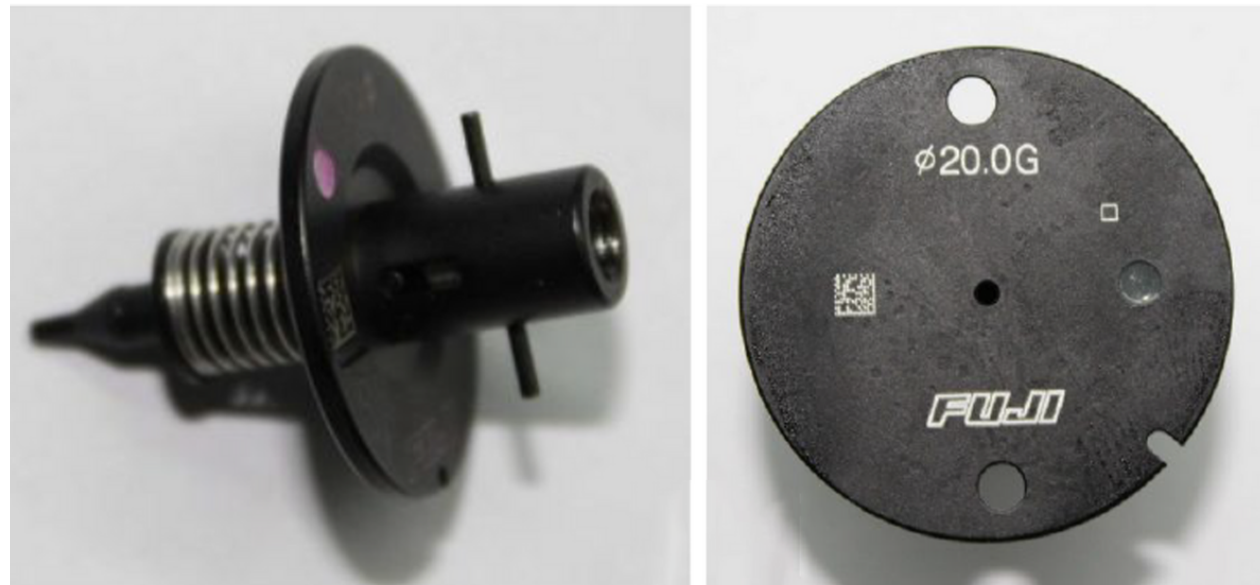

Fuji



SAMSUNG



Panasonic



Juki



YAHAMA

3. After receiving the order, we will prepare the products right away for you, once receive your payment, we will deliver in a short time. Maximum shortened the time for customers to get the goods.

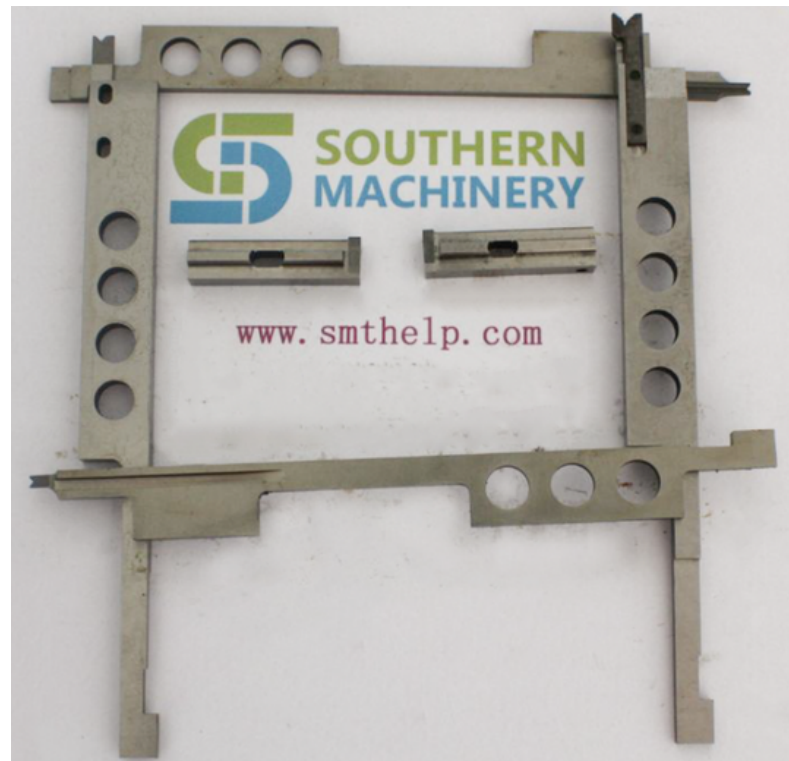

4. Carefully check the quality before every shipment.

5. Strict requirements on packing. Ensure that after let customers received parts not only won't disappoint, instead of happy.



Please visit

[www.smthelp.com](http://www.smthelp.com)

Find us more

<https://www.facebook.com/autoinsertion>

Know more our team

<https://cn.linkedin.com/in/smtsupplier>

Welcome to our factory in Shenzhen China

See more machine working videos, please Youtube [Auto Insertion](#)

Google

Auto+insertion, to get more informations

Looking forward to your email

[info@smthelp.com](mailto:info@smthelp.com)