

How to Depanelize LED Metal Core PCB

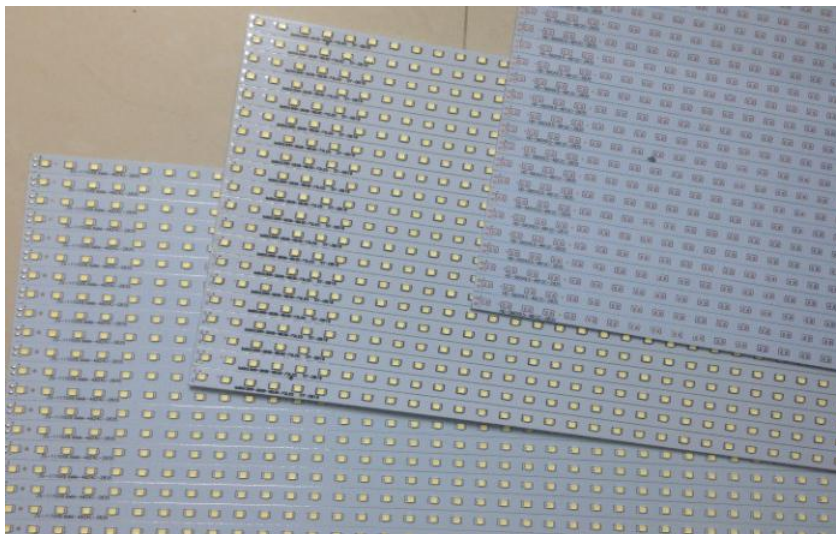

SOUTHERN MACHINERY S-D601 LED MCPCB depanelizer

- Ideal for singulating metal core LED panels stress- free.
- The multiplecutter mechanism ensures a smooth and precise cut inside the V-Groove slot.
- Three pairs of precision beveled blades.
- The upper blade is adjustable to eliminate stress and deformation between board layers.
- Utilizing the panel guides, the panel is aligned to safely transport the panel forward between the blades avoiding misalignment issue

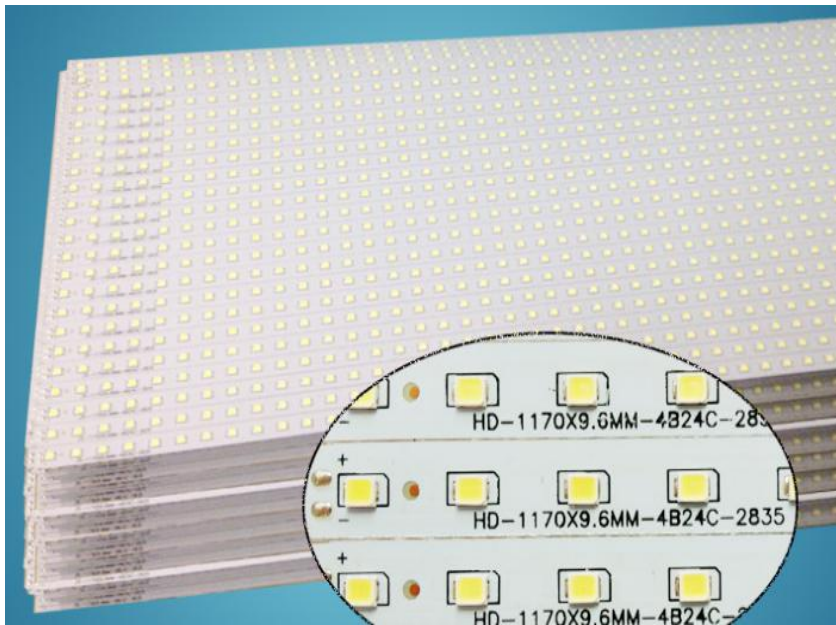
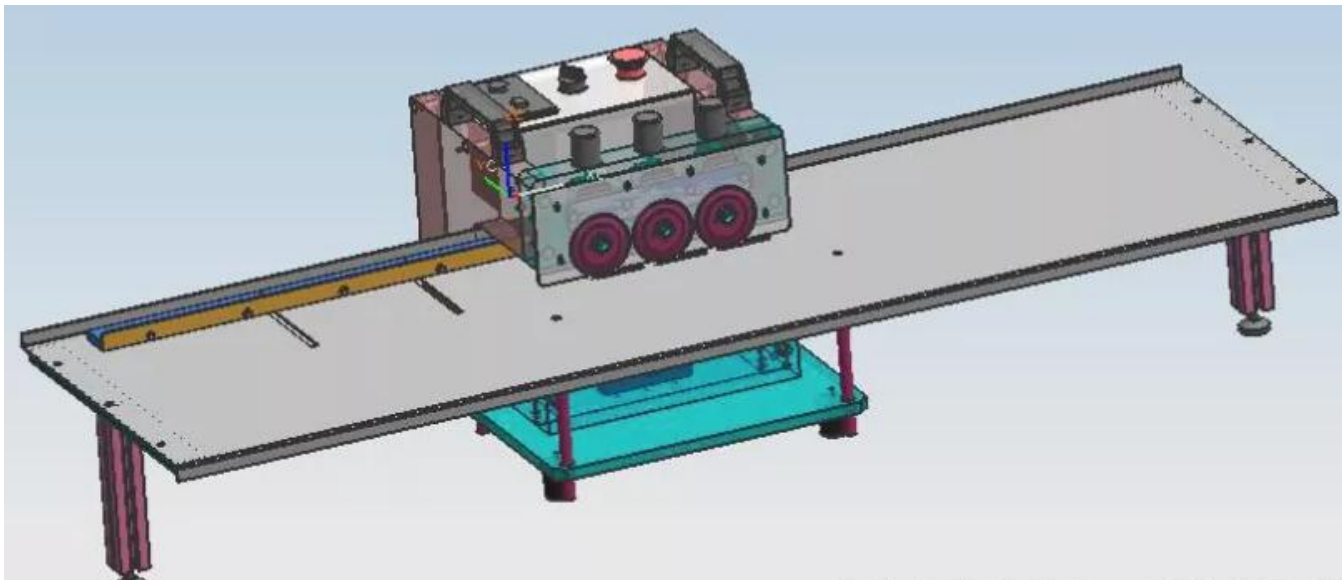

S-D601 Specifications

- Panel thickness:0.5–3mm
- Panel length:Unlimited
- Speed:80~500mm/s
- Cutter material: SKH7HSS
- Power:220V/50HZ/60W
- Dimensions:400x280x210mm(LWH)
(*)2.4M base plate standard.
- Weight: 36Kg



S-D601 Features

1. Three pairs of precision beveled cutting blades can ensure the board does not bend , or deform

2. Guide can be adjusted vertically to suit different LED boards/LED strip

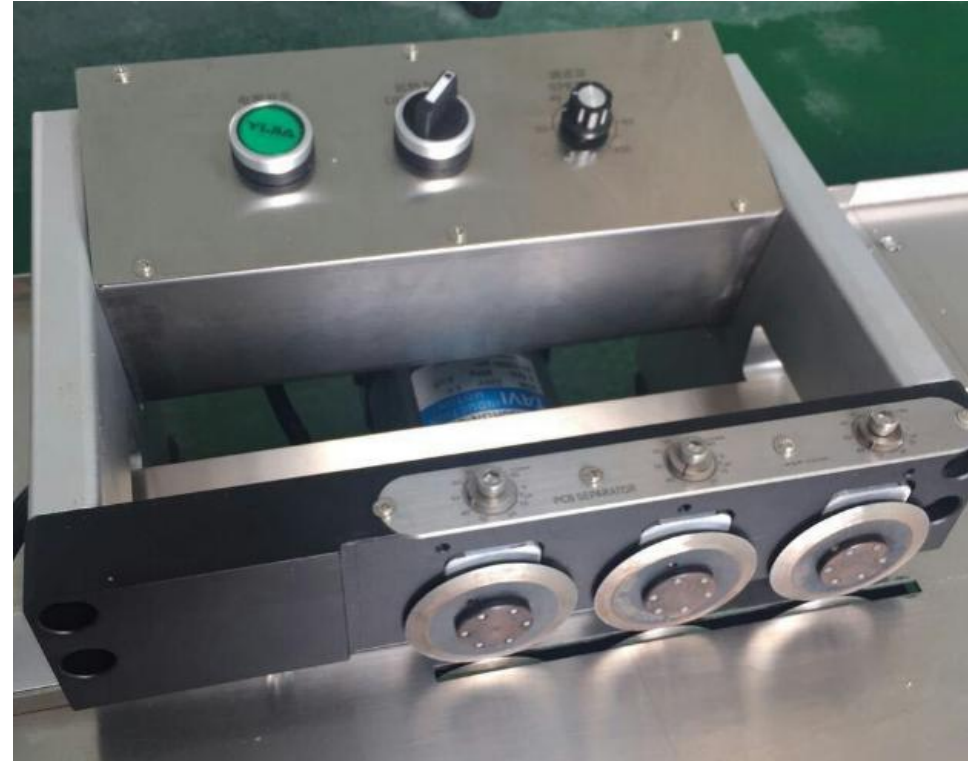

3. Depth between upper circular blades can be precisely adjusted to reduce stress on score-line edge and blade wear LED strip

4. Upper and lower circular blades can be resharpened

S-D601 working video

no need training, easy to operate



Machine Packing for Overseas

- Vacuum packing -- avoid rusting
- Dry protection
- Fumigation-free wooden -- green custom declare

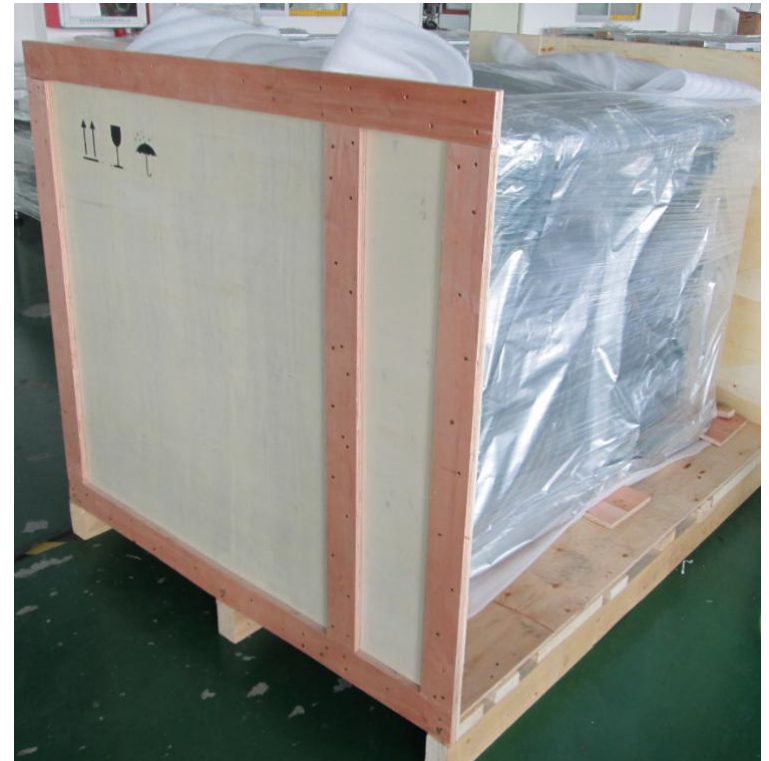
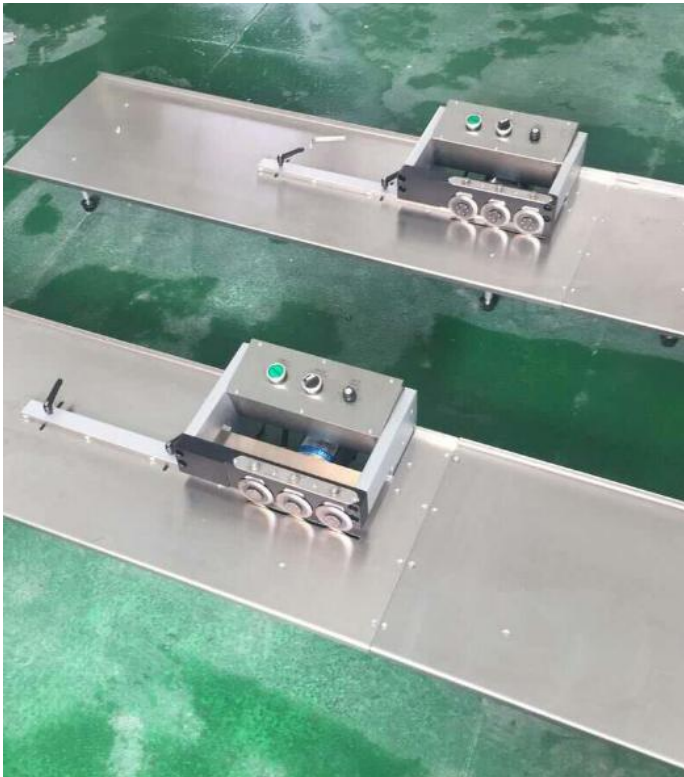

1, PCB Details:

- **Material: FPC, MC, FR2,FR4**
- **PCB Size: Length*Width*Thickness**
- **Is there V-Groove Line or connected with dots**
- **Max parts / components high?**
- **Min distance between V-Groove line & component**
- **Required output ? (pcs/hour)**
- **Samples / Drawings available?**

2, Mode of transport: EXW, FOB, CIF

3, Port of destination

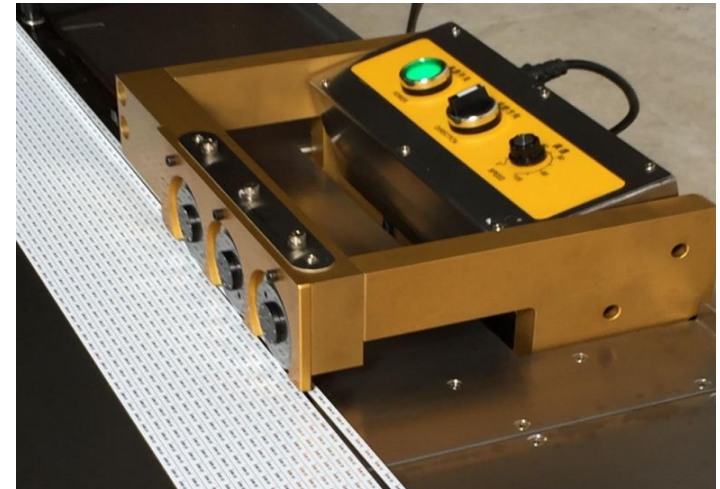

- 1, Please visit : www.smthelp.com
- 2, Find us more: <https://www.facebook.com/autoinsertion>
- 3, Know more our team:
<https://cn.linkedin.com/in/smtsupplier>
- 4, Welcome to our factory in Shenzhen China
- 5, Look at more machine running
video: <https://www.youtube.com/jasonwuSMT>
- 4, See more in Google: Auto+Insertion