

# SM-UV106CM Precision UV Curing System

Technical Integration & Operational Logic for EMS Specialists



# The 98% Solution: Universal Adhesive Compatibility



## Standard UV Glue

Full spectrum coverage for standard ultraviolet-curing adhesives.

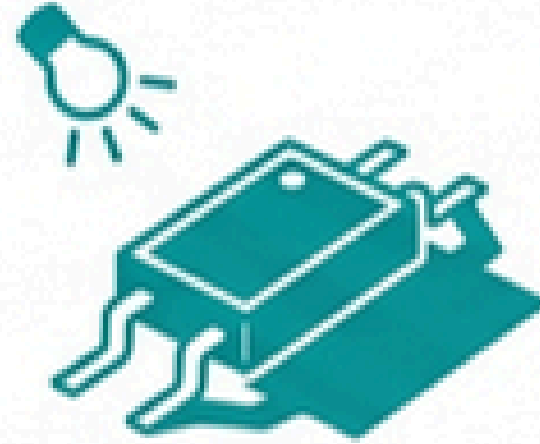

## Light & Shadow Glue

Specialized support for dual-cure adhesives, ensuring polymerization in 'shadow' areas blocked from direct light.

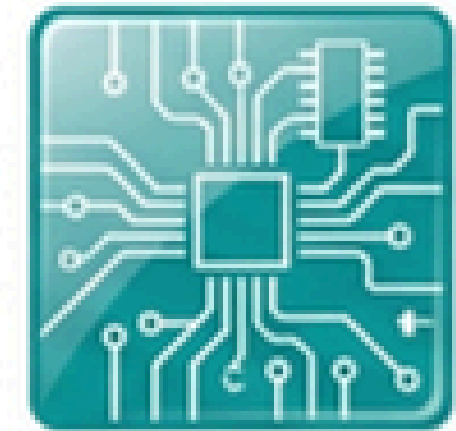

## Surface Protection

Engineered for SMT encapsulants (e.g., EC-9519) and PCB surface paints.

**Key Insight: Capable of curing >98% of market adhesives.**

Designed to minimize changeover times between different PCB assemblies in a high-mix EMS environment.

# Signal Logic & Line Integration (SMEMA)

**Connector Type:** Standard SMEMA interface for seamless integration with Panasonic, JUKI, and Yamaha lines.

## Input X2 (Front Machine Request)

- Signal: "Front machine has board".
- Logic: The oven accepts the board only when the conveyor is clear.

## Input X6 (Rear Machine Ready)

- Signal: "Rear machine has board".
- Logic: The oven holds the cured board at the exit until the downstream machine (AOI or Unloader) signals "Ready".

Prevents board crashes and pile-ups through active signal monitoring.

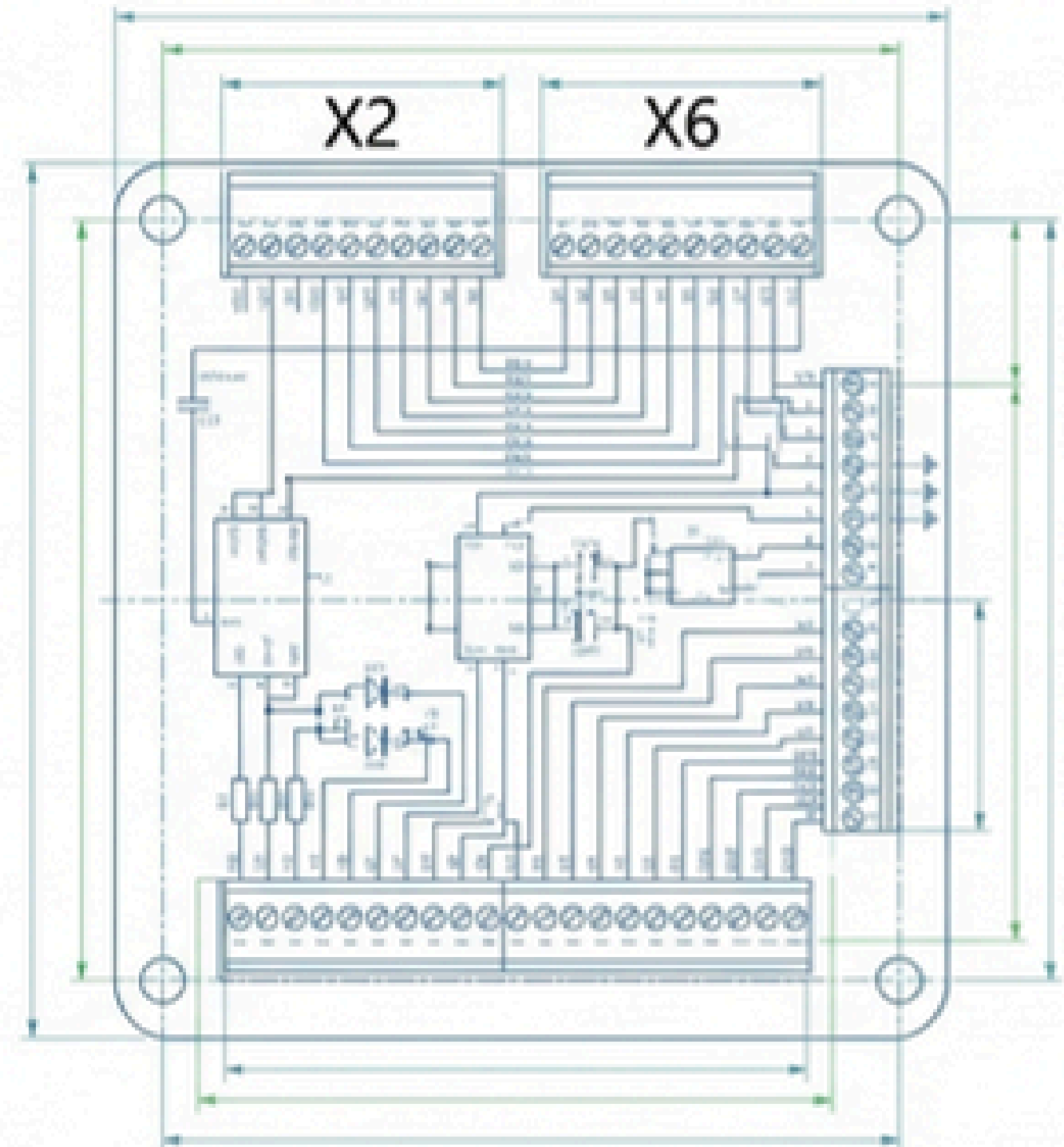

# Precision Transport Under Thermal Load

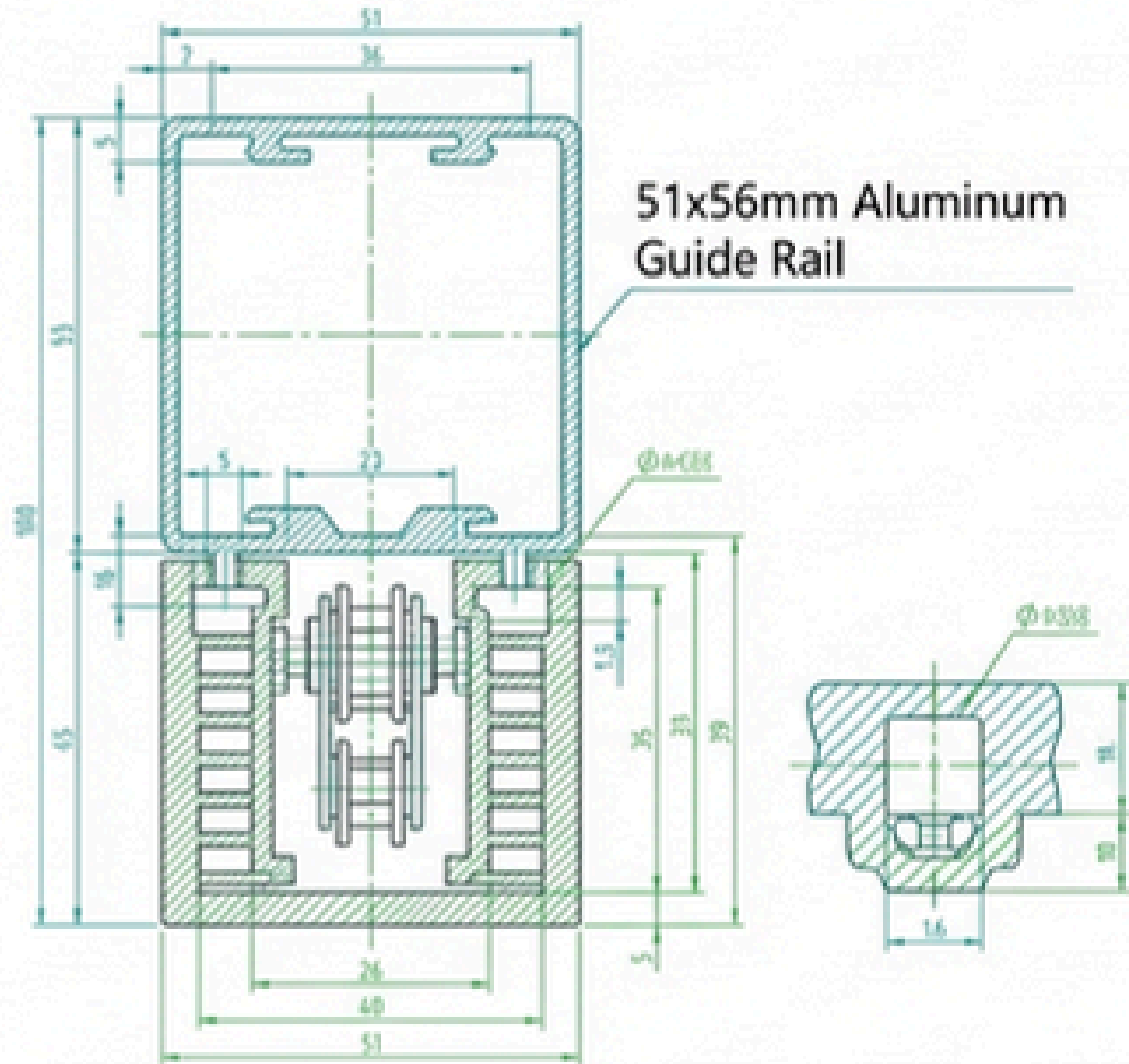

## Transmission Specifications

- Type: 3mm Chain or Mesh Belt options
- Direction: L→R Standard (Customizable)
- Speed Range: 700–2000mm/min (Stepless adjustment)

## Feature Focus: Suspension Width Adjustment System

**Advantage:** Specialized high-strength design isolates the rail from thermal expansion.

**Benefit:** Eliminates "Thermal Deformation." The rail width (adjustable 50-450mm) remains constant even during 24/7 high-temperature shifts, preventing board drops or jams.

# The Energy Source: Electrodeless Lamp Technology

## Core Capability:

1KW to 6KW Stepless Power Adjustment.

## Technical Insight:

Unlike fixed-power mercury lamps, the electrodeless system allows the operator to dial in the exact energy density required for the specific film thickness.

## Performance Metrics:

- Irradiation Height: Recommended 100~120mm
- Stability: Independent light module design ensures consistent UV output over the lamp's lifespan.

## Operator Value:

Energy savings during low-load cycles and prevention of component scorching on sensitive PCBA.

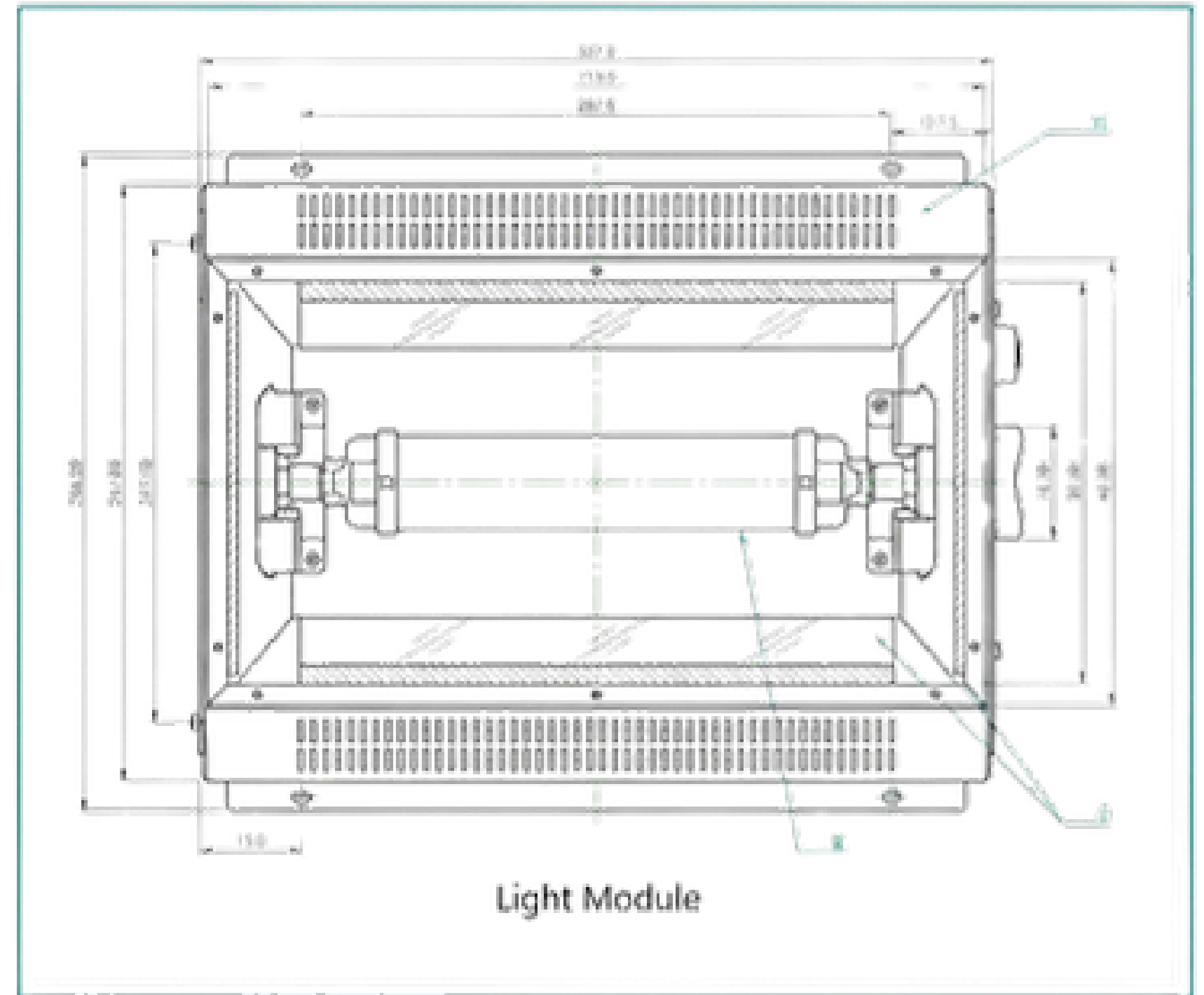

# Conquering the “Shadow Effect”

## The Problem:

- High-density PCBs create blind spots where direct UV line-of-sight is blocked by tall components.

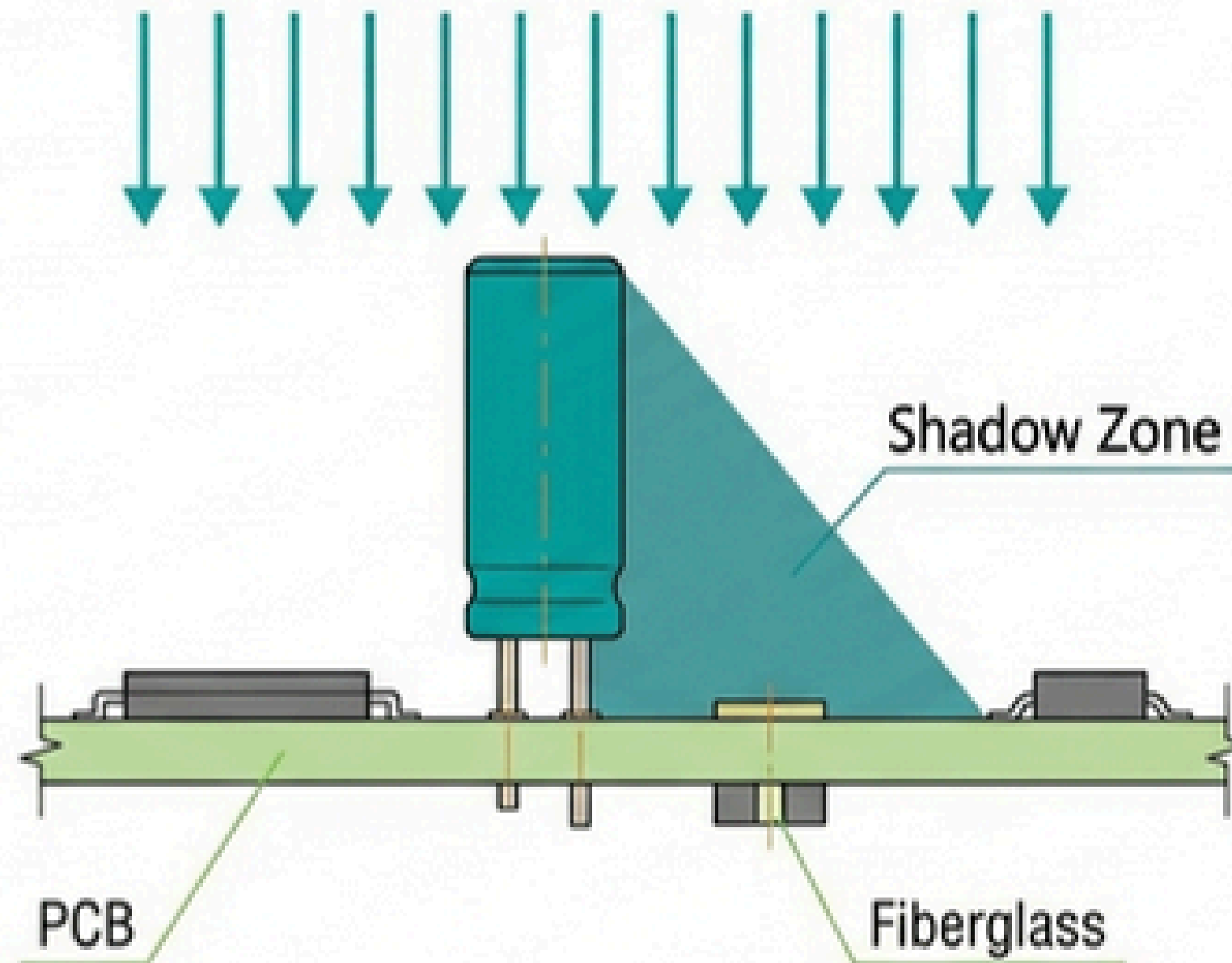

## The Solution:

- The SM-UV106CM is calibrated for ‘Light and Shadow’ adhesives (dual-cure chemistry).

## Result:

- Ensures full polymerization even in undercut areas or beneath components.

## Outcome:

- Zero ‘wet spots’ on the exit side, preventing contamination of the AOI or functional test fixtures.

# The Thermal Cycle: Cure & Cool

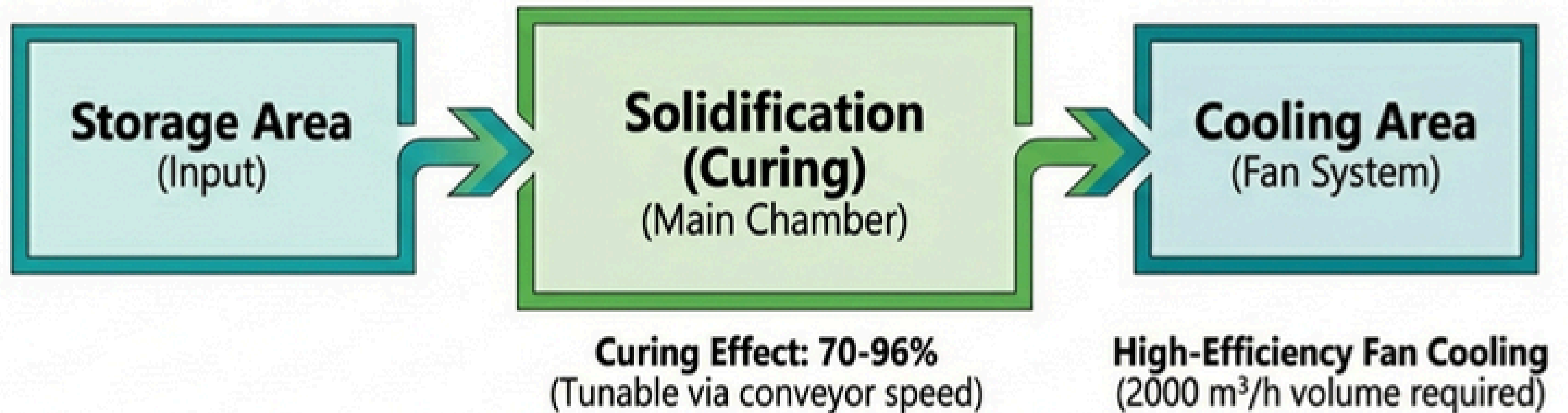

## Why Cooling Matters:

Rapidly reduces board temperature post-cure. Boards exit the oven cool enough to be handled immediately by the Unloader or AOI, preventing warping or solder joint stress during mechanical handling.

# Operational Logic & Control Interface

## Control Modes:

- **Standard:** Switch Control + Stepless Knobs (Robust, simple)
- **Optional:** PLC + Touch Screen (Recipe storage)

## Startup Sequence (SOP):

1. **Power On:** System energizes.
2. **Mercury Lamp Switch (SB2):** Lamp ignites.
3. **Warm-Up:** System waits ~1 minute for lamp to reach operating temp.
4. **Fan Start:** Cooling system engages automatically (P2.11/P2.12 Inverter Parameters).

**Benefit:** Defined logic prevents cold-starts and extends lamp life.

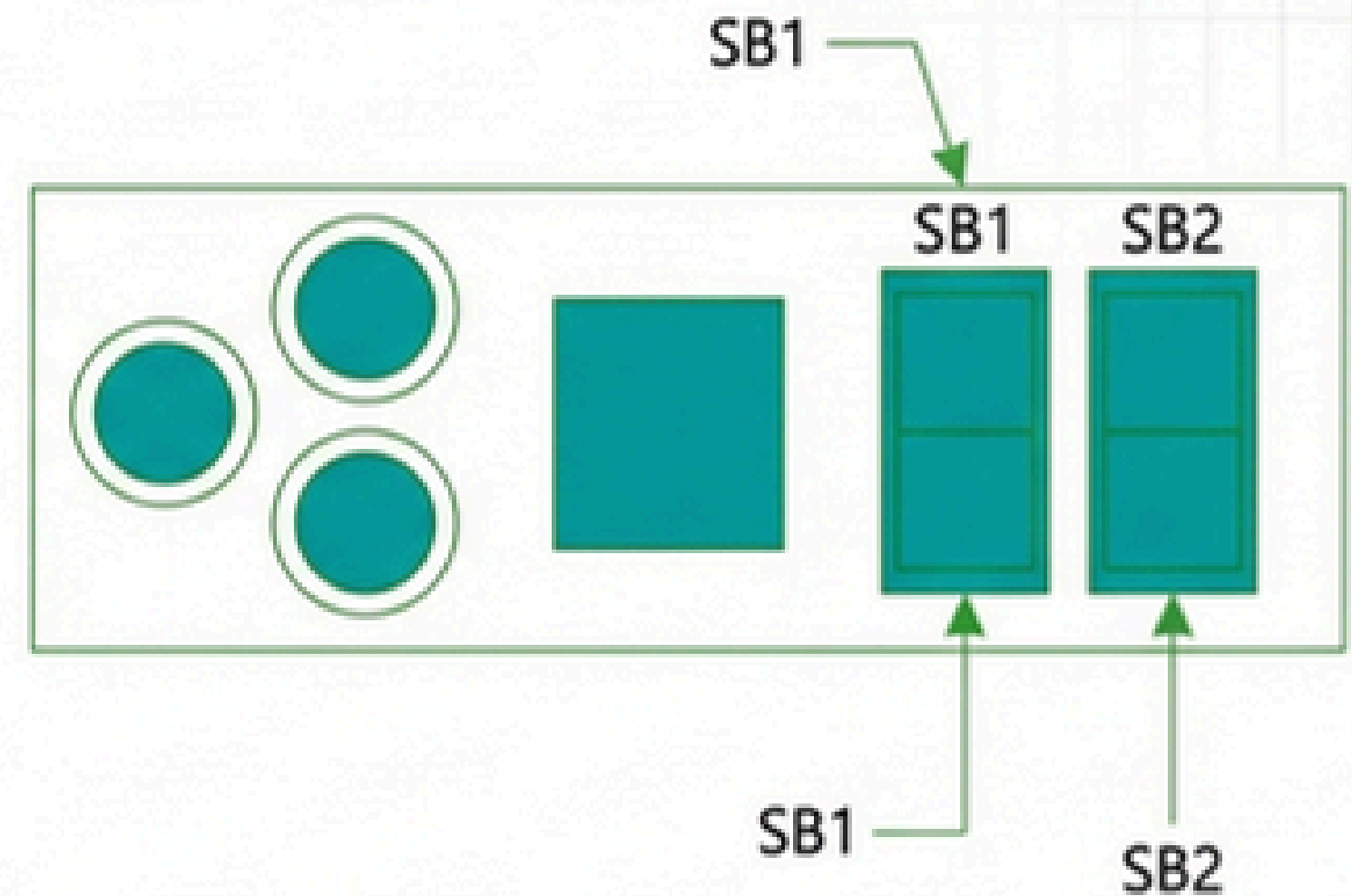

# Active Safety & Alarm Systems

## Fully Closed Cycle Control

The transmission system is interlocked with the curing engine to prevent stalled boards under heat.

## Thermal Protection

Voice-activated buzzer and auto-cutoff if the working area exceeds set temperature limits.

## UV Shielding

Full enclosure design prevents UV leakage during operation.

## Smart Standby Mode

If the conveyor stops for 5 minutes, the lamp automatically drops to low-power standby (1.1KW) to prevent overheating and save energy.

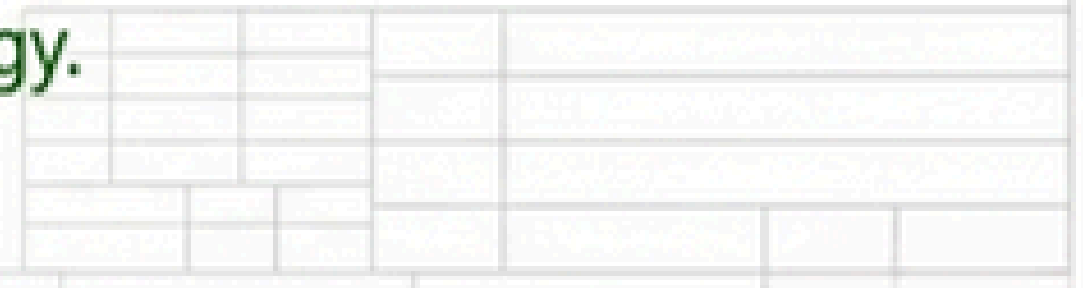
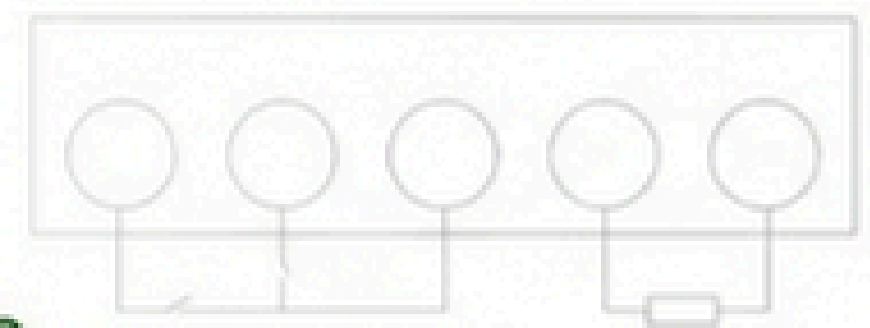
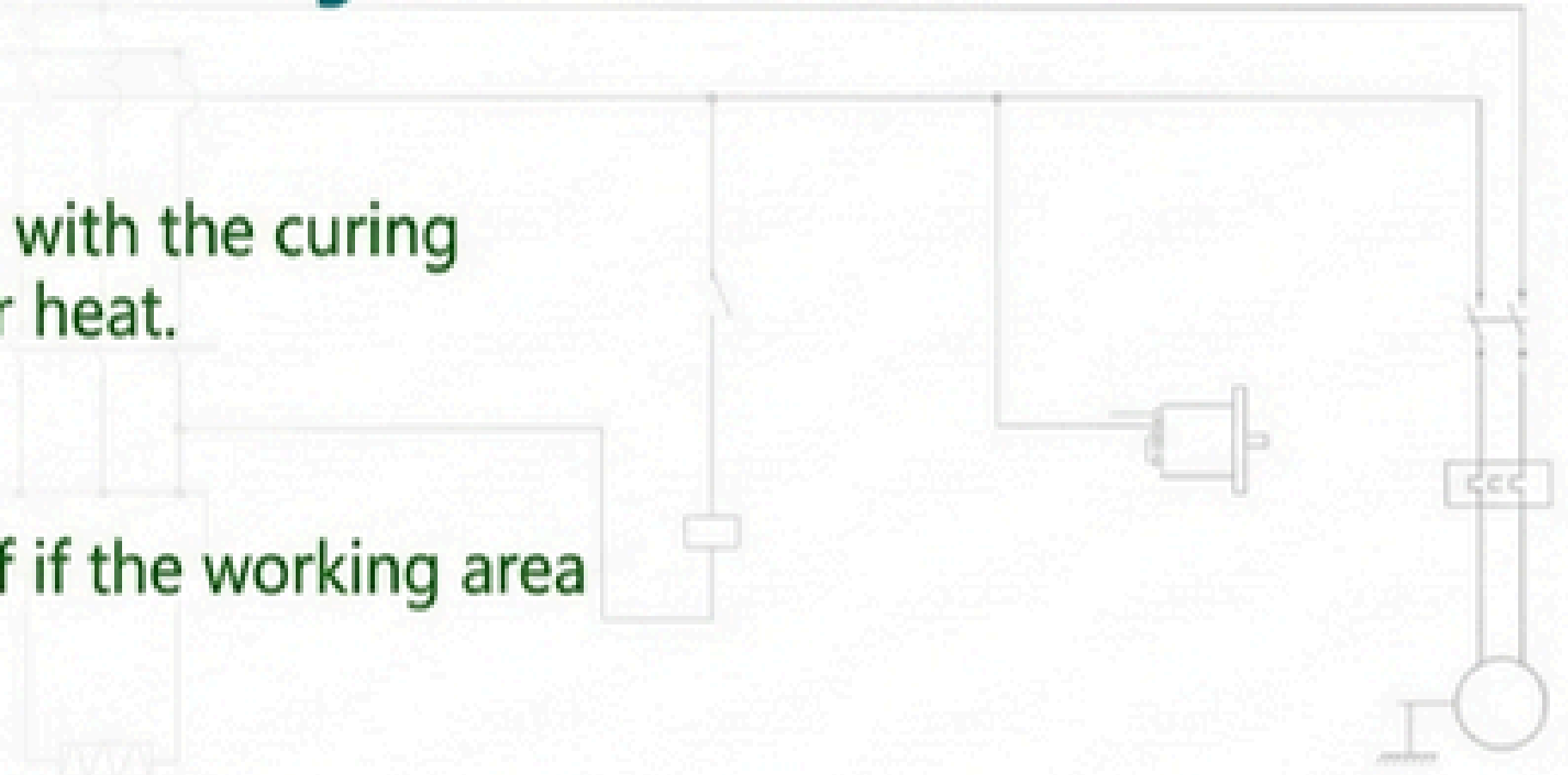

# Maintenance & Troubleshooting Logic

Symptom	Check / Component	Action
Whole machine has no power	Main Contactor (KM1) / Fuse	Check for blown fuse or contactor failure.
Conveyor not moving	Transport Relay / Stepper Motor (86 type)	Check for chain jams or motor failure.
Lamp not striking	SB2 switch / Warm-up timer	Verify warm-up sequence.

## Routine Care

- Lubricate transmission chain.
- Clean "Light Eye" sensors (Entry/Exit).
- Verify ventilation pipe connection.

# Technical Specifications Summary

## Facility Requirements

- **Power:** 380V, 50Hz, 3-Phase 4-Wire
- **Total Power:** 7KW
- **Ventilation:** Required (External exhaust connection)

## Machine Metrics

- **Dimensions:** 1600(L) × 1200(W) × 1400(H) mm
- **Weight:** ~200 KG
- **Max PCB Width:** 450mm
- **Conveyor Height:** 900 ± 20mm (SMEMA Standard)

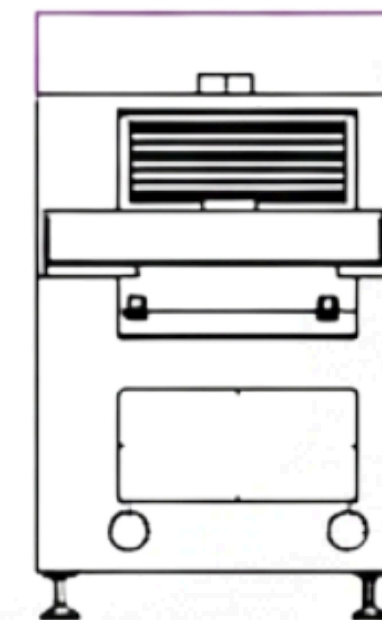
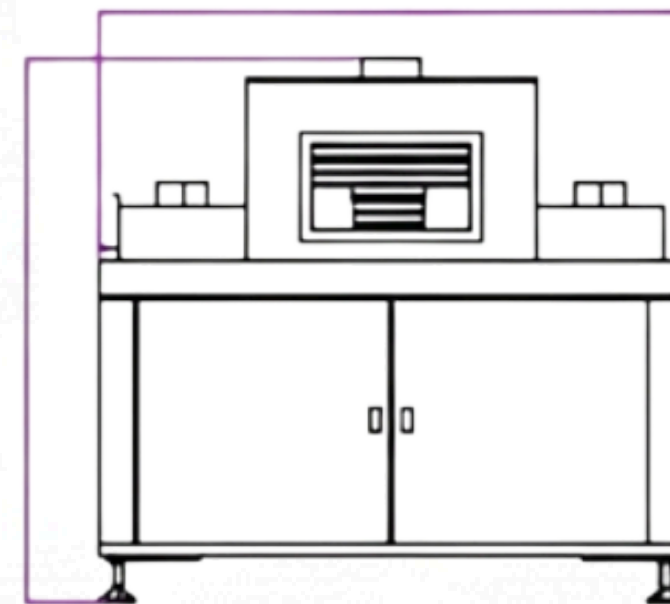
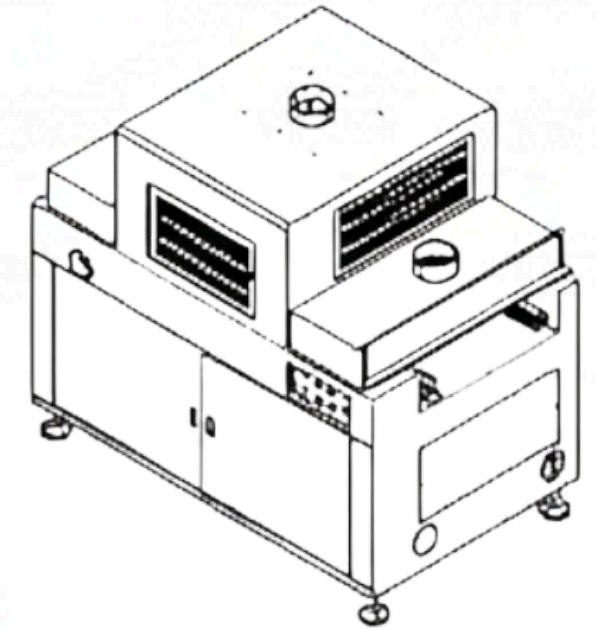
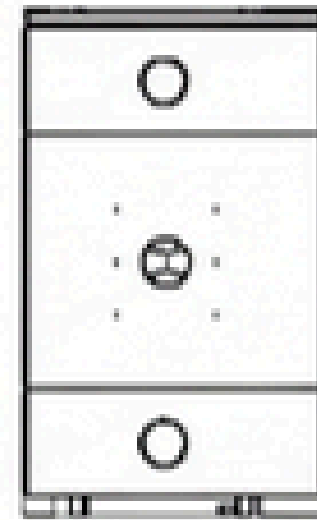



Proven reliability for 237+ EMS clients globally.

# Mastery Over the Cure

## Spare Parts

- Direct access to Mercury tubes, Stepper motors, and Sensors.

## Global Support

- Technical support channels available worldwide.

## Customization

- Tailored configurations for special line layouts.

**Visit [SMThelp.com](http://SMThelp.com) for full schematics and digital manuals.**